

Vehicle Standards Bulletin N° 14

National Code of Practice for Light Vehicle Construction and Modification

ADR SECOND EDITION COMPLIANCE CHECKLIST (All Vehicles Except Motor Cycles and Mopeds)

CODE LO1

CHECKLIST LO1-2

This checklist is called up by Code LO1 of Section LO *Vehicle Standards Compliance* and is intended to assist. The checklist applies to Second Edition ADR category vehicles only.

Unless otherwise shown, *Effective Dates* given for each ADR in this checklist apply to Passenger Vehicles.

Refer to Section LO *Vehicle Standards Compliance* for more detailed information on effective dates for all vehicle ADR categories. Alternatively, effective dates may be found at the following website:

<http://rvcs.dotars.gov.au/>

The Australian Vehicle Standards Rules (AVSR) allows a vehicle built to comply with a Second Edition ADR to comply with a more recent version of the ADR or in certain circumstances, with a relevant clause of the AVSR. This means that a vehicle may be certified to comply with these more recent requirements.

Where this occurs the appropriate section of the checklist must be annotated accordingly near the checklist ADR heading by the signatory performing the certification.

For example where ADR 7 *Hydraulic Brake Hoses* are certified against ADR 42/04, the ADR 7 checklist heading must be annotated in a similar manner to that shown below:

ADR 7 - HYDRAULIC BRAKE HOSES (*COMPLIES WITH ADR 42/04*).

Certain individual requirements contained within the Second Edition ADRs are now no longer mandatory. In these circumstances the vehicle does not need to be modified to the more recent standards for compliance purposes. For example, the requirement for unleaded fuel labelling is no longer mandatory in ADRs 37, 40 and 41. In this case, the unleaded fuel labels do not need to be removed if they are already fitted.

Australian Design Rules Compliance – Second Edition

| | | |
|-----|----------------|-----------|
| VIN | Certificate N° | Signature |
|-----|----------------|-----------|

Australian Design Rules Compliance – Second Edition

CHECKLIST LO1-2

AUSTRALIAN DESIGN RULES COMPLIANCE – SECOND EDITION

CODE LO1

(N/A = Not Applicable, Y=Yes, N=No)

ADR 1 - REVERSING SIGNAL LAMPS

Effective date 1 Jan 1972

| | | |
|-----------------------|---|---|
| 1. | Are reversing lamps fitted and do they operate continuously only when reverse gear is selected? | Y <input type="checkbox"/> N <input type="checkbox"/> |
| 2. | Are the reversing lamps white or amber? | Y <input type="checkbox"/> N <input type="checkbox"/> |
| 3. | Number of lamps one or two? (Circle) | |
| Compliance with rule: | | Y <input type="checkbox"/> N <input type="checkbox"/> |

ADR 2 - DOOR LATCHES AND HINGES

Effective date 1 Jan 1971

| | | |
|-----------------------|--|--|
| Compliance with rule: | | N/A <input type="checkbox"/> |
| | Does the vehicle have doors with: | |
| 1. | two latch positions, a fully latched position and a secondary latched position? | Y <input type="checkbox"/> N <input type="checkbox"/> N/A <input type="checkbox"/> |
| 2. | locks on all side doors and operating mechanism in the interior? | Y <input type="checkbox"/> N <input type="checkbox"/> N/A <input type="checkbox"/> |
| 3. | rear door locks? | Y <input type="checkbox"/> N <input type="checkbox"/> N/A <input type="checkbox"/> |
| 4. | rear door locks prevent their opening from inside and outside? | Y <input type="checkbox"/> N <input type="checkbox"/> N/A <input type="checkbox"/> |
| 5. | rear door locks that prevent opening from outside and, inside by engagement of <i>Child Safety Locks</i> ? | Y <input type="checkbox"/> N <input type="checkbox"/> N/A <input type="checkbox"/> |
| Compliance with rule: | | Y <input type="checkbox"/> N <input type="checkbox"/> |

| | | |
|-----|----------------|-----------|
| VIN | Certificate N° | Signature |
|-----|----------------|-----------|

Australian Design Rules Compliance – Second Edition

ADR 3, 3A- SEAT ANCHORAGES FOR MOTOR VEHICLES

Effective date 1 Jan 1971 and 1 Jan 1977

| | | |
|-----------------------|---|--|
| Compliance with rule: | | N/A <input type="checkbox"/> |
| 1. | Do all hinged seats or seat backs have a self-locking restraining device and release control provided?. | Y <input type="checkbox"/> N <input type="checkbox"/> N/A <input type="checkbox"/> |
| 2. | Where a seat must hinge or fold to permit access to or egress from another seat position, is there a release control readily accessible to the occupant of any seat immediately behind that seat? | Y <input type="checkbox"/> N <input type="checkbox"/> N/A <input type="checkbox"/> |
| Compliance with rule: | | Y <input type="checkbox"/> N <input type="checkbox"/> N/A <input type="checkbox"/> |

ADR 4 to 4D- SEATBELTS

Effective dates 1 Jan 1969, 1974, 1975, 1976 and 1984 respectively.

| | | |
|-----------------------|--|--|
| Compliance with rule: | | N/A <input type="checkbox"/> |
| 1. | Are new seatbelts fitted? | Y <input type="checkbox"/> N <input type="checkbox"/> N/A <input type="checkbox"/> |
| 2. | Are they ADR compliant? | Y <input type="checkbox"/> N <input type="checkbox"/> N/A <input type="checkbox"/> |
| 3. | If they are of an alternate standard are they of an equivalent ADR standard? | Y <input type="checkbox"/> N <input type="checkbox"/> N/A <input type="checkbox"/> |
| 4. | Do seatbelts appear to be in a good working and acceptable condition? | Y <input type="checkbox"/> N <input type="checkbox"/> N/A <input type="checkbox"/> |
| 5. | Are retractor lap sash seatbelts fitted on all outboard seating positions as required by the vehicle's ADR category and year of manufacture (except folding third row cargo area ADR 5)? | Y <input type="checkbox"/> N <input type="checkbox"/> N/A <input type="checkbox"/> |
| 6. | Are there lap belts at least for all other seating position? | Y <input type="checkbox"/> N <input type="checkbox"/> N/A <input type="checkbox"/> |
| 7. | For swivelling seats, have seatbelt assemblies been provided for all positions in which the seat may be locked? | Y <input type="checkbox"/> N <input type="checkbox"/> N/A <input type="checkbox"/> |
| 8. | Do all buckles have a quick-release? | Y <input type="checkbox"/> N <input type="checkbox"/> N/A <input type="checkbox"/> |
| 9. | Are release instructions printed legibly on the front of the buckle? | Y <input type="checkbox"/> N <input type="checkbox"/> N/A <input type="checkbox"/> |
| 10. | Any free end of strap of a seatbelt: | |
| | Prevented from passing through an adjuster? | Y <input type="checkbox"/> N <input type="checkbox"/> N/A <input type="checkbox"/> |
| | Have at least 25mm available grip when fully extended? | Y <input type="checkbox"/> N <input type="checkbox"/> N/A <input type="checkbox"/> |
| | For <i>Outboard Seating Positions</i> adjacent to a door, restrained against another strap? | Y <input type="checkbox"/> N <input type="checkbox"/> N/A <input type="checkbox"/> |
| 11. | Is the buckle component of the retracting strap accessible? | Y <input type="checkbox"/> N <input type="checkbox"/> N/A <input type="checkbox"/> |

| | | |
|-----|----------------------------|-----------|
| VIN | Certificate N ^o | Signature |
|-----|----------------------------|-----------|

Australian Design Rules Compliance – Second Edition

| | | |
|-----------------------|--|--|
| 12. | Is the buckle component of the non-retracting part of seatbelt accessible, and for individual front seats buckle component is rigid? | Y <input type="checkbox"/> N <input type="checkbox"/> N/A <input type="checkbox"/> |
| 13. | Is there a positive feature to restrain outboard buckles? | Y <input type="checkbox"/> N <input type="checkbox"/> N/A <input type="checkbox"/> |
| 14. | Has information been provided that includes location and instructions for use? | Y <input type="checkbox"/> N <input type="checkbox"/> N/A <input type="checkbox"/> |
| Compliance with rule: | | Y <input type="checkbox"/> N <input type="checkbox"/> |

ADR 5A, 5B –SEATBELT ANCHORAGES

Effective date 1 Jan 1969 and 1 Jan 1975

| | | |
|-----------------------|---|--|
| Compliance with rule: | | N/A <input type="checkbox"/> |
| 1. | Seatbelt anchorages fitted for all seating positions for lap sash and lap belts? | Y <input type="checkbox"/> N <input type="checkbox"/> N/A <input type="checkbox"/> |
| 2. | All outboard seating positions include an upper anchorage (except where third row folding seats where cargo space provided. (refer 1))? | Y <input type="checkbox"/> N <input type="checkbox"/> N/A <input type="checkbox"/> |
| 3. | Do all lap anchor points on opposite sides of <i>Seating Reference Plane</i> have a minimum separation at least 165mm? | Y <input type="checkbox"/> N <input type="checkbox"/> N/A <input type="checkbox"/> |
| Compliance with rule: | | Y <input type="checkbox"/> N <input type="checkbox"/> |

ADR 6, 6A - DIRECTION TURN SIGNALS LAMPS

Effective date 1 Jan 1973 and 1 Jan 1981

| | | |
|-----------------------|--|--|
| Compliance with rule: | | N/A <input type="checkbox"/> |
| 1. | Are direction turn signals lamps front, rear and side fitted? | Y <input type="checkbox"/> N <input type="checkbox"/> N/A <input type="checkbox"/> |
| 2. | Is their colour amber? | Y <input type="checkbox"/> N <input type="checkbox"/> N/A <input type="checkbox"/> |
| 3. | Is their position and visibility 45 degrees inboard and 80 degrees outboard front and rear? | Y <input type="checkbox"/> N <input type="checkbox"/> N/A <input type="checkbox"/> |
| 4. | If fitted, does the rear mounted tyre carrier not interfere with visibility as required in item 3? | Y <input type="checkbox"/> N <input type="checkbox"/> N/A <input type="checkbox"/> |
| 5. | Do side repeater lamps have geometric visibility from 5 degrees (see diagram below). | Y <input type="checkbox"/> N <input type="checkbox"/> N/A <input type="checkbox"/> |

| | | |
|-----|----------------|-----------|
| VIN | Certificate N° | Signature |
|-----|----------------|-----------|

Australian Design Rules Compliance – Second Edition

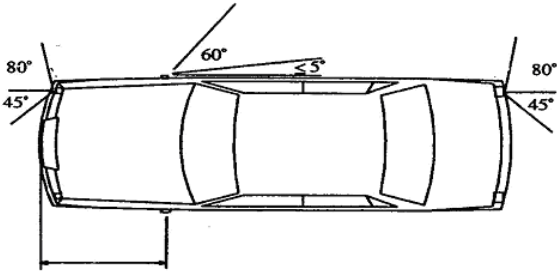
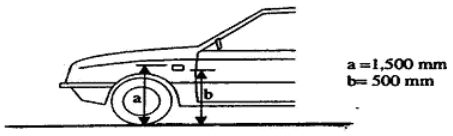
| | |
|---|--|
|  |  |
| Compliance with rule: | Y <input type="checkbox"/> N <input type="checkbox"/> |

ADR 7 - HYDRAULIC BRAKE HOSES

Effective date 1 Jan 1970

| | | |
|-----------------------|--|--|
| Compliance with rule: | | N/A <input type="checkbox"/> |
| 1. | Do brake hoses comply with SAE J1401, FMVSS 106 or DO? . (Circle) | Y <input type="checkbox"/> N <input type="checkbox"/> N/A <input type="checkbox"/> |
| 2. | For any one brake hose, identify: Location: _____ Marking: _____ | |
| 3. | Are all brake hoses in a good condition and not perished or damaged? | Y <input type="checkbox"/> N <input type="checkbox"/> N/A <input type="checkbox"/> |
| Compliance with rule: | | Y <input type="checkbox"/> N <input type="checkbox"/> |

ADR 8 – SAFETY GLASS SAFETY GLAZING MATERIAL

Effective date 1 July 1971

| | | |
|-----------------------|--|--|
| Compliance with rule: | | N/A <input type="checkbox"/> |
| 1. | Is all glazing suitably marked? | Y <input type="checkbox"/> N <input type="checkbox"/> N/A <input type="checkbox"/> |
| 2. | Has the windscreen glass been marked as being laminated? | Y <input type="checkbox"/> N <input type="checkbox"/> N/A <input type="checkbox"/> |

| | | |
|-----|----------------------------|-----------|
| VIN | Certificate N ^o | Signature |
|-----|----------------------------|-----------|

Australian Design Rules Compliance – Second Edition

| | |
|--|---|
| 3. | State glazing standard and approval No: _____ |
| | • Windscreen marking: _____ |
| | • Driver's side window marking: _____ |
| | • Rear window: _____ |
| Compliance with rule: Y <input type="checkbox"/> N <input type="checkbox"/> | |

ADR 10A, 10B - STEERING COLUMNS

Effective date 1 Jan 1971 and 1 Jan 1973

| | |
|--|--|
| Compliance with rule: N/A <input type="checkbox"/> | |
| 1. | Does the steering column have a collapsible element? Y <input type="checkbox"/> N <input type="checkbox"/> N/A <input type="checkbox"/> |
| Compliance with rule: Y <input type="checkbox"/> N <input type="checkbox"/> | |

ADR 11 - INTERNAL SUN VISORS

Effective date 1 Jan 1972

| | |
|--|---|
| Compliance with rule: N/A <input type="checkbox"/> | |
| 1. | The sun visors have no rigid material edges of less than 3mm? Y <input type="checkbox"/> N <input type="checkbox"/> N/A <input type="checkbox"/> |
| 2. | Are the sun visors fitted padded with energy absorption material? Y <input type="checkbox"/> N <input type="checkbox"/> N/A <input type="checkbox"/> |
| Compliance with rule: Y <input type="checkbox"/> N <input type="checkbox"/> | |

ADR 12 - GLARE REDUCTION IN THE FIELD OF VIEW

Effective date 1 Jan 1973

| | |
|--|--|
| Compliance with rule: N/A <input type="checkbox"/> | |
| <p>Are all surfaces of the following items dull metal surface or non-metallic?</p> <ul style="list-style-type: none"> • windscreen wiper arms and blades; • internal windscreen mouldings; • horn ring and hub of steering wheel; • internal rear vision mirror frame and mounting bracket; and • steering column mounted control levers and gear selector quadrants. | Y <input type="checkbox"/> N <input type="checkbox"/> N/A <input type="checkbox"/> |
| Compliance with rule: Y <input type="checkbox"/> N <input type="checkbox"/> | |

| | | |
|-----|----------------|-----------|
| VIN | Certificate N° | Signature |
|-----|----------------|-----------|

Australian Design Rules Compliance – Second Edition

ADR 14 - REAR VISION MIRRORS

Effective date 1 Jan 1972

| | | |
|-----------------------|---|--|
| Compliance with rule: | | N/A <input type="checkbox"/> |
| 1. | Are the reflective surfaces of both the driver's side and the internal mirror flat? | Y <input type="checkbox"/> N <input type="checkbox"/> N/A <input type="checkbox"/> |
| 2. | Is the LHS external mirror <i>Flat</i> or <i>Convex</i> ? (circle one) | |
| 3. | Is the RHS external mirror adjustable from the driver's seating position? | Y <input type="checkbox"/> N <input type="checkbox"/> N/A <input type="checkbox"/> |
| 4. | Is the RHS external mirror not obscured by the unwiped portion of the windscreen? | Y <input type="checkbox"/> N <input type="checkbox"/> N/A <input type="checkbox"/> |
| Compliance with rule: | | Y <input type="checkbox"/> N <input type="checkbox"/> |

ADR 15 - DEMISTING OF WINDSCREENS

Effective date 1 Jan 1971

| | | |
|-----------------------|---|--|
| Compliance with rule: | | N/A <input type="checkbox"/> |
| 1. | Is a functioning windscreen demister provided for the driver's forward vision? | Y <input type="checkbox"/> N <input type="checkbox"/> N/A <input type="checkbox"/> |
| 2. | Is the fan air velocity sufficient to demist the windscreen in front of the driver? | Y <input type="checkbox"/> N <input type="checkbox"/> N/A <input type="checkbox"/> |
| Compliance with rule: | | Y <input type="checkbox"/> N <input type="checkbox"/> |

ADR 16 - WINDSCREEN WIPERS AND WASHERS

Effective date 1 Jan 1973

| | | |
|-----------------------|---|--|
| Compliance with rule: | | N/A <input type="checkbox"/> |
| 1 | Are the areas of windscreen immediately in front of the driver and the front seat passenger wiped satisfactory? | Y <input type="checkbox"/> N <input type="checkbox"/> N/A <input type="checkbox"/> |
| 2. | Are wiper and washer controls readily accessible to driver? | Y <input type="checkbox"/> N <input type="checkbox"/> N/A <input type="checkbox"/> |
| 3. | What is the wiper frequency? (Including intermittent cycles)._____ | |
| 4. | Is the windscreen washing system operational? | Y <input type="checkbox"/> N <input type="checkbox"/> N/A <input type="checkbox"/> |
| 5. | Is the washer bottle capacity at least 1 litre? | Y <input type="checkbox"/> N <input type="checkbox"/> N/A <input type="checkbox"/> |
| Compliance with rule: | | Y <input type="checkbox"/> N <input type="checkbox"/> |

| | | |
|-----|----------------|-----------|
| VIN | Certificate N° | Signature |
|-----|----------------|-----------|

Australian Design Rules Compliance – Second Edition

ADR 18, 18A - INSTRUMENTATION

Effective date 1 Jan 1973 and 1 Jan 1981

| | | |
|-----------------------|---|--|
| Compliance with rule: | | N/A <input type="checkbox"/> |
| 1. | Is the speedometer on the driver's side and are all visual indicators readily visible by the driver? | Y <input type="checkbox"/> N <input type="checkbox"/> N/A <input type="checkbox"/> |
| 2. | Is there contrast between the speed indicating element colour and background? | Y <input type="checkbox"/> N <input type="checkbox"/> N/A <input type="checkbox"/> |
| 3. | Are all essential gauges and indicators other than warning lamps provided with variable intensity illumination? | Y <input type="checkbox"/> N <input type="checkbox"/> N/A <input type="checkbox"/> |
| 4. | Is the vehicle speed indicated in km/h only? If NO is major scale in km/h? | Y <input type="checkbox"/> N <input type="checkbox"/> N/A <input type="checkbox"/> |
| 5. | Is the speedometer readily visible to the driver? | Y <input type="checkbox"/> N <input type="checkbox"/> N/A <input type="checkbox"/> |
| Compliance with rule: | | Y <input type="checkbox"/> N <input type="checkbox"/> |

ADR 20 - SAFETY RIMS

Effective date 1 July 1970

| | | |
|-----------------------|--|--|
| Compliance with rule: | | N/A <input type="checkbox"/> |
| 1 | Are all wheel rims on passenger vehicles able to retain a deflated tyre in event of sudden loss of pressure? | Y <input type="checkbox"/> N <input type="checkbox"/> N/A <input type="checkbox"/> |
| 2 | Are rims marked accordingly as required by the ADR? | Y <input type="checkbox"/> N <input type="checkbox"/> N/A <input type="checkbox"/> |
| Compliance with rule: | | Y <input type="checkbox"/> N <input type="checkbox"/> |

ADR 21 - INSTRUMENT PANELS

Effective date 1 Jan 1973

| | | |
|-----------------------|--|--|
| Compliance with rule: | | N/A <input type="checkbox"/> |
| 1. | Is the area of the instrument panel left of the steering wheel padded? | Y <input type="checkbox"/> N <input type="checkbox"/> N/A <input type="checkbox"/> |
| 2. | Do the interior compartment door latches operate satisfactorily and remain closed when tested? | Y <input type="checkbox"/> N <input type="checkbox"/> N/A <input type="checkbox"/> |
| Compliance with rule: | | Y <input type="checkbox"/> N <input type="checkbox"/> |

| | | |
|-----|----------------------------|-----------|
| VIN | Certificate N ^o | Signature |
|-----|----------------------------|-----------|

Australian Design Rules Compliance – Second Edition

ADR 22, 22A - HEAD RESTRAINTS

Effective date 1 Jan 1972 and 1 Jan 1975

| | | |
|-----------------------|--|--|
| Compliance with rule: | | N/A <input type="checkbox"/> |
| 1. | Are there head restraints provided for each front outboard seat? | Y <input type="checkbox"/> N <input type="checkbox"/> N/A <input type="checkbox"/> |
| 2. | Is the width of the head restraint not less than 170mm for an individual seat and 250mm for a bench seat? | Y <input type="checkbox"/> N <input type="checkbox"/> N/A <input type="checkbox"/> |
| 3. | Is the top of any head restraint at least 750mm in height from the junction of the seat backrest and seating cushion, for any position of adjustment? (Refer to ADR for more exact measurements where dimensions are borderline or contested). | Y <input type="checkbox"/> N <input type="checkbox"/> N/A <input type="checkbox"/> |
| Compliance with rule: | | Y <input type="checkbox"/> N <input type="checkbox"/> |

ADR 23 to 23B – PNEUMATIC PASSENGER CAR TYRES

Effective date 1 Jan 1974, 1984 and 1986 respectively

| | | |
|-----------------------|--|--|
| Compliance with rule: | | N/A <input type="checkbox"/> |
| 1. | <p>For one tyre fitted, identify: (If tyre size different front and rear, complete for 1 front and 1 rear tyre)</p> <ul style="list-style-type: none"> Manufacturer or trade mark Fr _____ R _____ Tyre size, speed category and carcass construction symbols Fr _____ R _____ | |
| 2. | Is each tyre labelled on both sides, except for <i>Asymmetrical</i> Tyres that are at least labelled on the outer <i>Sidewalls</i> ? | Y <input type="checkbox"/> N <input type="checkbox"/> N/A <input type="checkbox"/> |
| 3. | Are there at least 4 tread wear indicators on each tyre? | Y <input type="checkbox"/> N <input type="checkbox"/> N/A <input type="checkbox"/> |
| Compliance with rule: | | Y <input type="checkbox"/> N <input type="checkbox"/> |

ADR 24, 24A - TYRE SELECTION

Effective date 1 Jan 1973 and 1 Jan 1986

| | | |
|-----------------------|---|--|
| Compliance with rule: | | N/A <input type="checkbox"/> |
| 1 | Are new tyres fitted? or | |
| | Do tyres fitted comply with <i>DOT</i> or <i>E</i> mark specifications? | Y <input type="checkbox"/> N <input type="checkbox"/> N/A <input type="checkbox"/> |

| | | |
|-----|----------------|-----------|
| VIN | Certificate N° | Signature |
|-----|----------------|-----------|

Australian Design Rules Compliance – Second Edition

| | | |
|-----------------------|---|--|
| 2. | Is a tyre placard of durable material permanently affixed to the vehicle? | Y <input type="checkbox"/> N <input type="checkbox"/> N/A <input type="checkbox"/> |
| 3. | Does the placard contains the following? | |
| | • For each nominated rim profile the recommended tyre size? | Y <input type="checkbox"/> N <input type="checkbox"/> N/A <input type="checkbox"/> |
| | • Recommended tyre pressures in kPa? and | Y <input type="checkbox"/> N <input type="checkbox"/> N/A <input type="checkbox"/> |
| | • Statement on load rating and speed category? | Y <input type="checkbox"/> N <input type="checkbox"/> N/A <input type="checkbox"/> |
| 4. | Are all tyres fitted to the vehicle of the same type of carcass construction? | Y <input type="checkbox"/> N <input type="checkbox"/> N/A <input type="checkbox"/> |
| Compliance with rule: | | Y <input type="checkbox"/> N <input type="checkbox"/> |

ADR 25, 25A - ANTI-THEFT LOCKS

Effective date 1 Jan 1972 and 1 Jan 1978

| | | |
|-----------------------|--|--|
| Compliance with rule: | | N/A <input type="checkbox"/> |
| 1. | Does the Switch position <i>Engine On</i> to <i>Anti-Theft</i> through <i>Engine Off</i> ? | Y <input type="checkbox"/> N <input type="checkbox"/> N/A <input type="checkbox"/> |
| 2. | Is the key removable only in the <i>anti-theft</i> position? | Y <input type="checkbox"/> N <input type="checkbox"/> N/A <input type="checkbox"/> |
| 3. | Is <i>Engine Off</i> position to <i>Anti-Theft</i> position possible by more than a single rotary or linear motion of the key, or if key removal activates the anti-theft device, is more than 2mm of movement required to activate? | Y <input type="checkbox"/> N <input type="checkbox"/> N/A <input type="checkbox"/> |
| 4. | With key in <i>Anti-Theft</i> position, is one of the following impossible? Steer vehicle / Engage forward drive gears / Release a brake? (Circle which is applicable). | Y <input type="checkbox"/> N <input type="checkbox"/> N/A <input type="checkbox"/> |
| Compliance with rule: | | Y <input type="checkbox"/> N <input type="checkbox"/> |

ADR 26 – VEHICLE ENGINE EMISSION

Effective date 1 Jan 1972

(This rule specifies limits for engine emissions at idle)

| | | |
|-----------------------|--|--|
| Compliance with rule: | | N/A <input type="checkbox"/> |
| 1. | Is the engine crankcase sealed to external escape? | Y <input type="checkbox"/> N <input type="checkbox"/> N/A <input type="checkbox"/> |
| 2. | Is all of the original emission equipment fitted and functional? | Y <input type="checkbox"/> N <input type="checkbox"/> N/A <input type="checkbox"/> |
| 3. | Is the engine in good condition and properly tuned? | Y <input type="checkbox"/> N <input type="checkbox"/> N/A <input type="checkbox"/> |
| 4. | Does the vehicle meet the <i>10 Second Smoke Emission Rule</i> ? | Y <input type="checkbox"/> N <input type="checkbox"/> N/A <input type="checkbox"/> |
| Compliance with rule: | | Y <input type="checkbox"/> N <input type="checkbox"/> |

| | | |
|-----|----------------------------|-----------|
| VIN | Certificate N ^o | Signature |
|-----|----------------------------|-----------|

Australian Design Rules Compliance – Second Edition

ADR 27 to 27C - VEHICLE ENGINE EMISSION CONTROL

Effective date 1 Jan 1974, 1 July 1976, 1 Jan 1982 and 1 Jan 1983.

(This rule specifies limits for engine emissions)

| | | |
|-----------------------|--|--|
| Compliance with rule: | | N/A <input type="checkbox"/> |
| 1. | Is all of the original emission equipment fitted and functional? | Y <input type="checkbox"/> N <input type="checkbox"/> N/A <input type="checkbox"/> |
| 2. | Is the engine in good condition and properly tuned? | Y <input type="checkbox"/> N <input type="checkbox"/> N/A <input type="checkbox"/> |
| 3. | Does the vehicle meet the <i>10 Second Smoke Emission Rule</i> ? | Y <input type="checkbox"/> N <input type="checkbox"/> N/A <input type="checkbox"/> |
| Compliance with rule: | | Y <input type="checkbox"/> N <input type="checkbox"/> |

ADR 28, 28A - MOTOR VEHICLE NOISE

Effective date 1 Jan 1974 and 1 July 1980

| | | |
|-----------------------|--|--|
| Compliance with rule: | | N/A <input type="checkbox"/> |
| 1. | Does the vehicle sound level measurement satisfy the AVSR level for the year of manufacture and does not sound unduly noisy? | Y <input type="checkbox"/> N <input type="checkbox"/> N/A <input type="checkbox"/> |
| 2. | Is the exhaust system in good condition with no leaks or corrosion? | Y <input type="checkbox"/> N <input type="checkbox"/> N/A <input type="checkbox"/> |
| 3. | Stationary Sound level measurement dB(A). <i>Test Result reading:</i> | |
| Compliance with rule: | | Y <input type="checkbox"/> N <input type="checkbox"/> |

ADR 29 - SIDE DOOR STRENGTH

Effective date 1 Jan 1977

| | | |
|-----------------------|--|--|
| Compliance with rule: | | N/A <input type="checkbox"/> |
| 1. | Do the side doors used for occupant protection have original impact intrusion bars or are there reinforcing bars installed; or is there an engineer's report confirming side door strength? Is the report available or attached? | Y <input type="checkbox"/> N <input type="checkbox"/> N/A <input type="checkbox"/> |
| Compliance with rule: | | Y <input type="checkbox"/> N <input type="checkbox"/> |

ADR 30 – DIESEL ENGINE EXHAUST SMOKE EMISSIONS

Effective date 1 July 1976

| | | |
|-----------------------|--|--|
| Compliance with rule: | | N/A <input type="checkbox"/> |
| 1. | Have all engine oil/fuel filters and injectors been serviced and have oils been changed? | Y <input type="checkbox"/> N <input type="checkbox"/> N/A <input type="checkbox"/> |



| | | |
|-----|----------------------------|-----------|
| VIN | Certificate N ^o | Signature |
|-----|----------------------------|-----------|

Australian Design Rules Compliance – Second Edition

| | | |
|-----------------------|--|--|
| 2. | Has an engine smoke or fuel air ratio test been conducted? (Is the test report attached)? | Y <input type="checkbox"/> N <input type="checkbox"/> N/A <input type="checkbox"/> |
| 3. | Is an engine label fitted and marked with month/year of manufacture? | Y <input type="checkbox"/> N <input type="checkbox"/> N/A <input type="checkbox"/> |
| 4. | Has the diesel engine exhaust smoke emission been adjusted to manufacturers specifications? | Y <input type="checkbox"/> N <input type="checkbox"/> N/A <input type="checkbox"/> |
| Compliance with rule: | | Y <input type="checkbox"/> N <input type="checkbox"/> |

ADR 31 - HYDRAULIC BRAKING SYSTEMS PASSENGER CAR BRAKES (PASSENGER CAR MA CATEGORY ONLY)

Effective date 1 Jan 1977

| | | |
|-----------------------|---|--|
| Compliance with rule: | | N/A <input type="checkbox"/> |
| 1. | Has the brake system been serviced, and are all disc pads/linings in serviceable condition? | Y <input type="checkbox"/> N <input type="checkbox"/> N/A <input type="checkbox"/> |
| 2. | Is the service brake system a split system? | Y <input type="checkbox"/> N <input type="checkbox"/> N/A <input type="checkbox"/> |
| 3. | Have adequate provisions been made for adjustment of service and park brake systems? | Y <input type="checkbox"/> N <input type="checkbox"/> N/A <input type="checkbox"/> |
| | • Combined reservoir for split system? | Y <input type="checkbox"/> N <input type="checkbox"/> N/A <input type="checkbox"/> |
| | • If yes, is there a divider fitted? | Y <input type="checkbox"/> N <input type="checkbox"/> N/A <input type="checkbox"/> |
| 4. | Is there an appropriate label on or near the brake fluid reservoir cap? | Y <input type="checkbox"/> N <input type="checkbox"/> N/A <input type="checkbox"/> |
| 5. | Has a service brake failure indicator lamp been fitted? | Y <input type="checkbox"/> N <input type="checkbox"/> N/A <input type="checkbox"/> |
| 6. | Is the labelling satisfactory with at least the word <i>BRAKE</i> , or ISO symbol  incorporated? | Y <input type="checkbox"/> N <input type="checkbox"/> N/A <input type="checkbox"/> |
| 7. | Is the park brake mechanical only? | Y <input type="checkbox"/> N <input type="checkbox"/> N/A <input type="checkbox"/> |
| 8. | Is the park brake indicator a separate lamp (S), or a combination unit (C) with service brake failure lamp? (Indicate S or C). | Y <input type="checkbox"/> N <input type="checkbox"/> N/A <input type="checkbox"/> |
| 9. | Is the labelling satisfactory with at least the words <i>PARK BRAKE</i> , <i>PARKING BRAKE</i> , or   incorporated? | Y <input type="checkbox"/> N <input type="checkbox"/> N/A <input type="checkbox"/> |
| Compliance with rule: | | Y <input type="checkbox"/> N <input type="checkbox"/> |

| | | |
|-----|----------------|-----------|
| VIN | Certificate N° | Signature |
|-----|----------------|-----------|

Australian Design Rules Compliance – Second Edition

ADR 34, 34A - CHILD RESTRAINT ANCHORAGES

Effective date 1 July 1976 and 1 Jan 1985

| | | |
|-----------------------|---|--|
| Compliance with rule: | | N/A <input type="checkbox"/> |
| 1. | Are child restraint anchorages provided for each applicable rear seating position? | Y <input type="checkbox"/> N <input type="checkbox"/> N/A <input type="checkbox"/> |
| 2. | Do the anchorages meet the Australian equivalent standards by inspection, comparison or test? (Circle one). | Y <input type="checkbox"/> N <input type="checkbox"/> N/A <input type="checkbox"/> |
| 3. | For positions where <i>Anchor Fitting</i> is provided, does the anchorage fitted have a 5/16 UNC thread? | Y <input type="checkbox"/> N <input type="checkbox"/> N/A <input type="checkbox"/> |
| 4. | Has sufficient clearance been provided around each <i>Fitting</i> to allow latching and unlatching of <i>Attaching Clip</i> ? | Y <input type="checkbox"/> N <input type="checkbox"/> N/A <input type="checkbox"/> |
| 5. | Have location information and instructions for use been provided? | Y <input type="checkbox"/> N <input type="checkbox"/> N/A <input type="checkbox"/> |
| 6. | Are the Child Restraint Anchorages more than 230mm rearward of the transverse <i>Seating Reference Plane</i> ? | Y <input type="checkbox"/> N <input type="checkbox"/> N/A <input type="checkbox"/> |
| 7. | <i>Do the child restraint anchorage/fittings lie within 40mm of the Seating Reference Plane?</i> | Y <input type="checkbox"/> N <input type="checkbox"/> N/A <input type="checkbox"/> |
| Compliance with rule: | | Y <input type="checkbox"/> N <input type="checkbox"/> |



ADR 35, 35A - COMMERCIAL VEHICLE BRAKING SYSTEMS

Effective date 1 Jan 1979 and 1 July 1980

| | | |
|-----------------------|---|--|
| Compliance with rule: | | N/A <input type="checkbox"/> |
| 1. | Has the brake system been serviced, and are all disc pads/linings in serviceable condition? | Y <input type="checkbox"/> N <input type="checkbox"/> N/A <input type="checkbox"/> |
| 2. | Are there service brakes on all wheels? | Y <input type="checkbox"/> N <input type="checkbox"/> N/A <input type="checkbox"/> |
| 3. | Is a secondary brake system provided? | Y <input type="checkbox"/> N <input type="checkbox"/> N/A <input type="checkbox"/> |
| 4. | If service brake is hydraulic, is it a split system? | Y <input type="checkbox"/> N <input type="checkbox"/> N/A <input type="checkbox"/> |
| | • Combined reservoir for split system? | Y <input type="checkbox"/> N <input type="checkbox"/> N/A <input type="checkbox"/> |
| | • If yes, has a divider been fitted? | Y <input type="checkbox"/> N <input type="checkbox"/> N/A <input type="checkbox"/> |
| 5. | Is there an appropriate label on or near the brake fluid reservoir cap? | Y <input type="checkbox"/> N <input type="checkbox"/> N/A <input type="checkbox"/> |
| 6. | Service brake failure indicator: | |

| | | |
|-----|----------------------------|-----------|
| VIN | Certificate N ^o | Signature |
|-----|----------------------------|-----------|

Australian Design Rules Compliance – Second Edition

| | | |
|-----------------------|---|--|
| | <ul style="list-style-type: none"> (1) Is there one provided? | Y <input type="checkbox"/> N <input type="checkbox"/> N/A <input type="checkbox"/> |
| | <ul style="list-style-type: none"> (2) Does the lamp activate as required? | Y <input type="checkbox"/> N <input type="checkbox"/> N/A <input type="checkbox"/> |
| 7. | Is the labelling satisfactory with at least the word <i>BRAKE</i> , or <i>ISO</i> symbol  incorporated? | Y <input type="checkbox"/> N <input type="checkbox"/> N/A <input type="checkbox"/> |
| 8. | Has an audible indicator been provided with a single brake power unit? | Y <input type="checkbox"/> N <input type="checkbox"/> N/A <input type="checkbox"/> |
| 9. | For system with brake power units, have separate gauges been provided for each reservoir? | Y <input type="checkbox"/> N <input type="checkbox"/> N/A <input type="checkbox"/> |
| Park Brake | | |
| 1. | Is there a satisfactory mechanical mechanism that holds the park brake in any applied position.? | Y <input type="checkbox"/> N <input type="checkbox"/> N/A <input type="checkbox"/> |
| 2. | Is this control separate from the service brake? | Y <input type="checkbox"/> N <input type="checkbox"/> N/A <input type="checkbox"/> |
| 3. | Are a minimum of 2 separate and distinct movements required to release the park brake? | Y <input type="checkbox"/> N <input type="checkbox"/> N/A <input type="checkbox"/> |
| | <ul style="list-style-type: none"> If N/A, has the system been designed to minimise the possibility of inadvertent release? | Y <input type="checkbox"/> N <input type="checkbox"/> |
| 4. | Park brake indicator a separate lamp (S), or a combined unit (C) with service brake failure lamp? (Circle S or C) . | Y <input type="checkbox"/> N <input type="checkbox"/> N/A <input type="checkbox"/> |
| 5. | Is the labelling satisfactory with at least the words <i>PARK BRAKE</i> , <i>PARKING BRAKE</i> , or   incorporated? | Y <input type="checkbox"/> N <input type="checkbox"/> N/A <input type="checkbox"/> |
| Compliance with rule: | | Y <input type="checkbox"/> N <input type="checkbox"/> |

ADR 36, 36A - EXHAUST EMISSION CONTROL FOR HEAVY DUTY VEHICLES

Effective date 1 July 1978 and 1 Jan 1988

(For Forward Control Passenger Car and Multi-Purpose Passenger Car Vehicle Categories (Over 2.7 tonnes GVM) only)

| | | |
|-----------------------|--|--|
| Compliance with rule: | | N/A <input type="checkbox"/> |
| 1. | Is a satisfactory label fitted to engine? | Y <input type="checkbox"/> N <input type="checkbox"/> N/A <input type="checkbox"/> |
| 2. | Is there a label approved by the Environmental Protection Agency (USA) attached to the engine? | Y <input type="checkbox"/> N <input type="checkbox"/> N/A <input type="checkbox"/> |
| 3. | Is ready access to idle air/fuel mixture screw prevented? | Y <input type="checkbox"/> N <input type="checkbox"/> N/A <input type="checkbox"/> |
| Compliance with rule: | | Y <input type="checkbox"/> N <input type="checkbox"/> |

| | | |
|-----|----------------------------|-----------|
| VIN | Certificate N ^o | Signature |
|-----|----------------------------|-----------|

Australian Design Rules Compliance – Second Edition

ADR 37 - VEHICLE EMISSION CONTROL

Effective date 1 Jan 1986

| | | |
|-----------------------|---|--|
| Compliance with rule: | | N/A <input type="checkbox"/> |
| 1. | Readily visible unleaded fuel label affixed near petrol filler inlet? (No Longer Mandatory) | Y <input type="checkbox"/> N <input type="checkbox"/> N/A <input type="checkbox"/> |
| 2. | Filler neck internal diameter more than 21.30mm and less than 23.6mm (for unleaded petrol nozzle only)? (No Longer Mandatory) | Y <input type="checkbox"/> N <input type="checkbox"/> N/A <input type="checkbox"/> |
| 3. | Label fitted in engine compartment? | Y <input type="checkbox"/> N <input type="checkbox"/> N/A <input type="checkbox"/> |
| 4. | Catalytic converter fitted and in good working condition? | Y <input type="checkbox"/> N <input type="checkbox"/> N/A <input type="checkbox"/> |
| 5. | IM240 engine emission test conducted? (Report attached?) (Applies only in Jurisdictions where this test is required). | Y <input type="checkbox"/> N <input type="checkbox"/> N/A <input type="checkbox"/> |
| Compliance with rule: | | Y <input type="checkbox"/> N <input type="checkbox"/> |

ADR 40 – LIGHT DUTY VEHICLE EMISSION

Effective date 1 Jan 1988

| | | |
|-----------------------|--|--|
| Compliance with rule: | | N/A <input type="checkbox"/> |
| 1. | Is there a readily visible unleaded fuel label affixed near the petrol filler inlet? (No Longer Mandatory) | Y <input type="checkbox"/> N <input type="checkbox"/> N/A <input type="checkbox"/> |
| 2. | Is the filler neck internal diameter more than 21.30mm and less than 23.6mm (for unleaded petrol nozzle only)? (No Longer Mandatory) | Y <input type="checkbox"/> N <input type="checkbox"/> N/A <input type="checkbox"/> |
| 3. | Is a label fitted in engine compartment displaying data on engine idle speed, ignition timing, cam dwell angle or contact breaker gap, transmission position, engine operation conditions and any other information required to enable engine adjustments to be correctly carried out will stop? | Y <input type="checkbox"/> N <input type="checkbox"/> N/A <input type="checkbox"/> |
| 4. | Is a catalytic converter fitted and in good working condition? | Y <input type="checkbox"/> N <input type="checkbox"/> N/A <input type="checkbox"/> |
| 5. | IM240 engine emission test conducted? (Report attached?) (Applies only in Jurisdictions where this test is required). | Y <input type="checkbox"/> N <input type="checkbox"/> N/A <input type="checkbox"/> |
| Compliance with rule: | | Y <input type="checkbox"/> N <input type="checkbox"/> |

| | | |
|-----|----------------|-----------|
| VIN | Certificate N° | Signature |
|-----|----------------|-----------|

Australian Design Rules Compliance – Second Edition

ADR 41 - MANDATORY OPERATION ON UNLEADED PETROL

Effective date 1 Jan 1988

Note 1: Vehicles that comply with ADR 37 or ADR 40 need not comply with ADR 41

Note 2: This is no longer a mandatory requirement but imported vehicles must be able to be operated on unleaded petrol

| | | |
|-----------------------|---|--|
| Compliance with rule: | | N/A <input type="checkbox"/> |
| 1. | Has an unleaded fuel label been affixed near petrol filler inlet(s)? (No Longer Mandatory) | Y <input type="checkbox"/> N <input type="checkbox"/> N/A <input type="checkbox"/> |
| 2. | Is the filler neck internal diameter more than 21.30mm and less than 23.6mm? (For unleaded petrol nozzle only). (No Longer Mandatory) | Y <input type="checkbox"/> N <input type="checkbox"/> N/A <input type="checkbox"/> |
| Compliance with rule: | | Y <input type="checkbox"/> N <input type="checkbox"/> |

VEHICLE DIMENSIONS

| | |
|---|---|
| Does the vehicle meet the relevant requirements of the AVSRs as they apply to vehicle dimensions? | Y <input type="checkbox"/> N <input type="checkbox"/> |
|---|---|

Note: If the answer to any question is **N (No)**, the compliance cannot be certified under Code LO1.

| | | |
|-----|----------------------------|-----------|
| VIN | Certificate N ^o | Signature |
|-----|----------------------------|-----------|