

Vehicle Standards Bulletin 14

NATIONAL CODE OF PRACTICE

for

LIGHT VEHICLE CONSTRUCTION

and

MODIFICATION

NATIONAL GUIDELINES

for

**THE INSTALLATION OF ELECTRIC
DRIVES**

IN MOTOR VEHICLES

Version 2.0 December 2009

Vehicle Standards Bulletin 14

National Code of Practice for Light Vehicle Construction and Modification (VSB 14)

Important Information for Users

Users of VSB 14 need to be aware that this document needs to be used in conjunction with the appropriate administrative requirements of the jurisdiction in which they wish to either register a vehicle or to obtain approval for a modification for an already registered vehicle. *Administrative requirements* include, amongst other things, processes for vehicle registration, obtaining exemptions, obtaining modification approvals, vehicle inspections, preparation and submission of reports and the payment of appropriate fees and charges.

If unsure of any of the requirements specified in VSB 14, or if more information is needed for any other issues concerning the administrative requirements, users should contact their relevant Registration Authority **prior** to commencing any work.

While VSB 14 provides advice on the construction of Individually Constructed Vehicles (ICVs) and the execution of modifications, it is not to be taken to be a design manual. Determination of component strength, performance, suitability and functionality must be either calculated or determined on a case by case basis by suitably qualified personnel experienced in each matter under consideration.

Users of VSB 14 also need to ensure that they refer to the most recent version of the relevant Section/s when working on a project. The version is identified by the version number and date on the face page of each Section. The version and date is also located in the footer of each page in each Section. On the website the version number is specified in the Section file name for easy identification.

If a project is taking a long time to complete, check the currency of the version you are using.

Users must be familiar with the provisions stated in the Preface and Introduction. These two Sections provide the necessary background information to assist users in understanding how VSB 14 is administered by Registration Authorities across Australia, on how it is structured, and the meaning of the types of modification codes specified in VSB 14. If not already done so, users should download them for study and reference.

Understanding these requirements is important to ensure that the correct processes are followed thereby reducing the likelihood of having work rejected by Registration Authorities.

Many of the Sections refer to other Sections within VSB 14 for further information or additional requirements. Users must read and apply all relevant Sections.

If in doubt about any issue concerning or contained in VSB 14, users should seek clarification from the appropriate State or Territory Registration Authority.

Please do not contact Vehicle Safety Standards (VSS) of the Federal Department of Infrastructure, Transport, Regional Development and Local Government in Canberra about VSB 14. VSS provides the website as a service only.

CONTENTS

BACKGROUND	5
TERMS AND REFERENCES.....	5
SCOPE	6
INTENT AND PURPOSE	6
RELATIONSHIP WITH THE LAWS OF AUSTRALIAN JURISDICTIONS	6
ADMINISTRATION	6
FUTURE DEVELOPMENTS	7
FUTURE REVISIONS	7
DATE AT WHICH THE DOCUMENT TAKES EFFECT	7
DOCUMENT FORMAT	7
REVISION HISTORY	8
NOTICE TO USERS OF VSB 14	8
ACKNOWLEDGMENTS	10
1 COMPLIANCE WITH REGULATIONS AND TECHNICAL AND SAFETY REQUIREMENTS	11
1.1 Compliance with Regulations.....	11
1.2 Individually Constructed Vehicles	11
1.3 Modified Vehicles	12
1.4 Australian Design Rules	12
2 TECHNICAL AND SAFETY REQUIREMENTS - ELECTRICAL.....	13
2.1 Electrical Definitions.....	13
2.2 Battery Type	13
2.3 Battery Restraint.....	13
2.4 Containment of Batteries.....	14
2.5 Venting of Battery Compartments (Class B Only).....	14
2.6 Labelling of Battery Compartments	14
2.7 Marking of Hazardous Voltage Components	14
2.8 Protection Against Electric Shock.....	14
2.9 Hazardous Voltage Isolation	15
2.10 Hazardous Voltage Disconnect.....	16
2.11 Hazardous Voltage Protection	17
2.12 Power Supply Priority.....	17
2.12.1 Auxiliary ELV	17
2.13 Vehicle Directional Control.....	17
2.14 Battery Management.....	18
2.15 Allowance for Australian Climatic Conditions.....	18
3 TECHNICAL AND SAFETY REQUIREMENTS - MECHANICAL	18
3.1 Changes to Vehicle Mass and Load Carrying Capacity	18
3.2 Brakes and Steering.....	19
3.3 Body or Chassis Modifications.....	20
3.4 Fuel System Modifications.....	20

4 OTHER ISSUES 21

4.1 Pedestrian Safety 21

4.2 Protection of Onboard Appliances 21

4.3 Electrical Installation Standards 21

4.4 Alternative Standard 21

4.5 Radio Frequency (RF) Remote Controls 21

Appendix A - International Protection (IP Codes)..... 23

DRAFT

National Code of Practice for the Construction and Modification of Light Vehicles

Guidelines for the Installation of Electric Drives in Road Vehicles

BACKGROUND

These Guidelines were originally sourced from documents prepared by the Roads and Traffic Authority of NSW and Queensland Transport. The original documents were further developed by the Department for Transport, Energy and Infrastructure (DTEI (SA)) in consultation with electrical engineers. The current version is a significant re-write which involved the assistance of Queensland Department of Transport and Main Roads, the WA chapter of the Australian Electric Vehicle Association and other enthusiasts across Australia.

These Guidelines have subsequently been endorsed by all Australian State and Territory Jurisdictions responsible for vehicle standards and the registration of vehicles for road use on xxx/2009.

TERMS AND REFERENCES

Within these Guidelines the following terms have the following meanings.

- May:* Indicates an option.
- Should:* Indicates a recommendation.
- Must:* Indicates mandatory.

Unless otherwise specified, *certification* in this document means *certification* to the requirements specified within VSB 14 and these Guidelines.

Signatory is a person who is accredited to, or registered with a Registration Authority for assessing and certifying modified vehicles for the purposes of registration.

(For the purposes of VSB 14 and these Guidelines, engineers and tradespersons involved in the approval process will be defined collectively under the generic term of *Signatory*. Wherever the term *Signatory* is used, it always means that the signatory referred to is one who has the necessary knowledge and technical expertise to assess and sign-off the matter under consideration).

All notes, diagrams, tables, headings and examples included in VSB 14 and in these Guidelines form part of VSB 14 and these Guidelines respectively.

SCOPE

These Guidelines apply to the Installation of Electric Drives in road vehicles.

Work performed to these Guidelines qualifies for VSB 14 Code LV1.

They apply to vehicles manufactured specifically for electric drive by individuals (i.e. Individually Constructed Vehicles (ICVs)) and to existing production vehicles that are to be converted from petrol, diesel or gas.

They form an integral part of VSB 14 and deal specifically with the overall installation of electric drives including their essential equipment such as battery packs, controls and safety devices.

The Guidelines also cover other safety related items such as the protection from electrical shock of users, bystanders, other road users, emergency rescue personnel and repairers.

These guidelines do not apply to ADR category L-group vehicles and motor cycles.

INTENT AND PURPOSE

These Guidelines are for the assistance of those who intend to install an electric drive in a passenger car or light commercial vehicle. Their ultimate aim is to ensure that each completed vehicle is safe for use on the road and that persons using or repairing the vehicle are unlikely to receive an electric shock.

RELATIONSHIP WITH THE LAWS OF AUSTRALIAN JURISDICTIONS

Subject to Federal laws and the laws of the States and Territories of Australia, these guidelines define standards of practice for the design, manufacture and/or modification of vehicles intended to be powered by electrical means. Other standards may be acceptable subject to adequate technical justification.

Nothing in these Guidelines is to be regarded as in any way limiting the powers and duties of the Minister, Chief Executive Officer or Road Transport Authority of the jurisdiction in question, or any agent or employee of that Officer, under the appropriate legislation of that jurisdiction.

Where any ADR, any Rule of the AVSR or any Australian Standard is referred to in these Guidelines, the appropriate ADR, Rule or Australian Standard should be read in full to avoid misinterpretation.

Each jurisdiction may have a different title for its adopted version of the AVSR and there may also be differences in rule or clause numbers.

Vehicle owners, registered operators, modifiers or builders must seek advice from the appropriate jurisdiction if in doubt about any of the above issues.

ADMINISTRATION

These Guidelines provide a set of uniform technical specifications for the installation of electric drives in motor vehicles that can be used across Australia. Jurisdictions have their own administrative procedures and requirements for the registration of new vehicles and for the approval of modifications. Owners and registered operators must familiarise themselves with the provisions of the jurisdiction in which they reside. Similarly, owners or registered operators of electrically powered vehicles who wish to transfer their vehicle license to another State or

Territory need to obtain relevant information from the jurisdiction in which the vehicle is to be garaged and registered.

FUTURE DEVELOPMENTS

These guidelines need to be recognised as being *live* and hence will need to be revised from time to time to include future developments arising from regulatory changes, improvements in technology and the development of alternative designs.

The guidelines may also be revised to improve editorial content.

FUTURE REVISIONS

Future revisions are the responsibility of the Australian Motor Vehicle Certification Board Working Party (the Working Party). Revisions, other than those of a legal or editorial nature, will be processed in consultation with relevant user groups.

The Working Party may consider applications from individuals concerning recommended revisions to the Guidelines. However, it is preferable that these are submitted after consideration by the appropriate user groups. In any event, the Working Party will consult widely before making a final decision on any proposed amendments to the Guidelines.

DATE AT WHICH THE DOCUMENT TAKES EFFECT

This document takes effect at the date of issue.

DOCUMENT FORMAT

This document is also available in electronic format and is available for download from the Department of Infrastructure, Transport, Regional Development and Local Government website.

www.infrastructure.gov.au

Sections of VSB 14 may also be downloaded from the same website. While VSB 14 may be downloaded in sections for the convenience of persons who may have a specific issue to address, any referenced Sections of VSB 14 that are applicable to the work being undertaken under these Guidelines must be read and applied also.

REVISION HISTORY

Revision	Comments
First Published	This document was approved in principle at the Australian Motor Vehicle Certification Board Working Party meeting held on 28 November 2005 and finally accepted, subject to a number of minor corrections, at a teleconference held on 17 January 2006.
Second Edition	This document was approved in principle at the Australian Motor Vehicle Certification Board Working Party meeting held on the XXX

NOTICE TO USERS OF VSB 14

Vehicle owners, registered operators, builders and modifiers of vehicles need to be aware that compliance with these Guidelines does not guarantee that a vehicle will be acceptable for registration in the case of an ICV, or for continued registration in the case of a modified registered production vehicle. If, for example, an ICV does not handle or brake satisfactorily or has any other feature that renders the vehicle unsafe or not roadworthy, it will not be accepted for registration.

Vehicle owners, registered operators, builders and modifiers of vehicles need to keep abreast of changes to legislation and vehicle registration policy in their jurisdiction, particularly in cases where a project is expected to take some years to complete. Changes to legislation before a vehicle is completed may mean that certain vehicles cannot be registered without appropriate modifications. Similarly, regulations pertaining to vehicle modifications, vehicle standards or registration policy may change causing certain vehicle modifications to become unacceptable in the future.

ACKNOWLEDGMENTS – VERSION 2

Further to the acknowledgements referenced in sub-section *Acknowledgments – Version 1*, the Australian Motor Vehicle Certification Board Working Party (AMVCB WP) wishes to thank all of the enthusiasts and organisations that contributed to the development of the second version of these Guidelines.

The AMVCB WP wishes to also acknowledge the key role played by the and Mr Rob Mason for acting as the national co-ordinator

Members of the AMVCB WP during the final review process included:

B Hendry	VicRoads (Vic)
D Leavy	RTA (NSW)
P Hunter	TAMS (ACT)
R Smith	DTEI (SA)
A Everingham	DTMR (Qld)
M Ross	DTMR (Qld)
B Muirhead	DPI (NT)
T Beard	DIER (Tas)
J Marcolina	DOT (WA)
R Middleton	DOT (WA)

Others assisting in the process included Dr G Scott (representing VicRoads), R Scholar (DITRD LG), and B Craig (RTA NSW).

ACKNOWLEDGMENTS – VERSION 1 (Published February 2006)

This document has been adopted by the Australian Motor Vehicle Certification Board Working Party (AMVCB WP) as the nationally accepted Guidelines for the installation of electric drives in Australia. These Guidelines form an integral part of the *National Code of Practice for Light Vehicle Construction and Modification*. The national code of practice is a major project currently being undertaken by the AMVCB WP.

The AMVCB WP wishes to acknowledge the key role played by Mr Rickman Smith (Department for Transport, Energy and Infrastructure (SA)) in developing these Guidelines in consultation with electrical engineers.

The project was managed by Mr John Dombrose on behalf of the AMVCB WP as an integral part of the *National Code of Practice for Light Vehicle Construction and Modification*.

Members of the AMVCB WP at the time of Publication include:

- Barry Hendry National Transport Commission
- Dr Gray Scott VicRoads
- Harry Vertsonis RTA (NSW)
- Rod Paule DUS (ACT)
- Roland Earl DTEI (SA)
- Robert Gibson Transport QLD
- Simon Saunders DPI (NT)
- Tony Beard DIER (Tas)
- John Dombrose DPI (WA)

1 COMPLIANCE WITH REGULATIONS AND TECHNICAL AND SAFETY REQUIREMENTS

1.1 Compliance with Regulations

ICVs must comply with the intent of the ADRs applicable to the ADR category and date of manufacture of each ICV.

Modified vehicles must continue to comply with the applicable ADRs according to each vehicle's ADR category and date of manufacture and also to the applicable AVSR.

1.2 Individually Constructed Vehicles

All ICVs must be built to comply with applicable codes specified in the VSB 14, Section LO to ensure compliance with the intent of the applicable ADRs according to the ICV's ADR category and date of manufacture.

As these Guidelines specifically cover electric drive issues only, builders or modifiers must refer to VSB 14 for more detailed information about vehicle modifications and ICV construction.

Section LO *Vehicle Standards Compliance* of VSB 14 outlines the minimum requirements for the assessment and certification of compliance with the ADRs for ICVs, Section LO also provides additional information about the ADRs, their applicability dates and *reasons for rejection*.

VSB 14 also has other sections under which modifications or vehicle construction can be shown to be in conformity with the ADRs.

A summary of the Section LO codes and checklists are listed below in Table 1.

Table 1 Codes that may be Certified in Section LO

Code Designation	Subject
LO1	Australian Design Rule Compliance
	Checklist LO1-1 ADR Compliance Summary
	Checklist LO1-2 – Second Edition
	Checklist LO1-3 - Third Edition MA, MB and MC
	Checklist LO1-4 - Third Edition MD, NA and NB.
LO2	ICV Passenger Cars and Derivatives
LO3	Personally Imported Vehicle Compliance
LO3	Personally Imported Vehicle Compliance Checklist
LO4	ICV Tricycle LEM1
LO4	ICV Tricycle LEM1 Checklist (Refer to Guidelines)

LO5	ICV Tricycle LEP1
LO5	ICV Tricycle LEP1 Checklist (Refer to Guidelines)
LO6	Street Rods
LO6	Street Rods Checklist (Refer to Guidelines)

1.3 Modified Vehicles

Vehicles modified to operate on electric power must comply with the AVSR. (Each jurisdiction has an equivalent set of vehicle standards).

The AVSR require vehicles to continue to comply with ADRs that were applicable to the vehicle in question according to its date of manufacture and ADR category.

The AVSR also has some additional in-service requirements such as limitations on window tinting, tyre wear, tyre selection, etc.. In order to ensure that modifications comply with the relevant provisions, please refer to the appropriate section/s of VSB 14.

It is important that all components be appropriately chosen so as to maintain a high degree of reliability and performance which will reduce the risk of breakdowns and hence the risk of impeding or interfering with the normal flow of traffic.

1.4 Australian Design Rules

As stated in clause 1.1, modified vehicles must meet the same design and safety requirements that applied to the original vehicle when it was manufactured. Where any system governed by an ADR is altered, it is necessary to show that the original requirements of the rule, or a later version, are still met.

Outlined below are requirements and/or components of the vehicle that may be affected by the modifications and that may require re-certification, testing and/or data to show continuing compliance for the modified vehicle. This is not an exhaustive list and other modifications may also affect ADR compliance.

- **Seat Anchorages (ADR 3x, 3/...)**, seatbelt anchorages (**ADR 5x, 5/...**) and child restraint anchorages (**ADR 34x, 34/...**) – any structural alteration made in the vicinity of the seat or seatbelt mountings, or the child restraint anchorages, may reduce their strength;
- **Occupant Protection (ADRs 10x, 10/..., 21, 21/..., 29, 29/..., 69/..., 72/... and 73/...)** - structural alterations, particularly at the front of the vehicle, the removal of the original engine or large increases in vehicle mass made by the addition of the traction batteries and motors, may affect the energy absorption characteristics of the vehicle structure, instrument panel or steering column;
- **Demisting of Windscreens (ADR 16, 42/...)** – the removal of the engine will necessitate the provision of an alternative source of heat for demisting air (or, perhaps, alternative demisting arrangements). A performance comparable to the original demisting system must be maintained;
- **Motor Vehicle Noise (ADRs 28x, 28/... and 83/...)** – in general, electric vehicles are quieter than those fitted with internal combustion engines. Alternative gearboxes, chain

drives and some electric control apparatus may increase noise levels and attention must be given to ensuring that this does not result in excessive external noise;

- **Emissions (ADRs 26, 27x, 30, 30/..., 37, 37/..., 79/... and 80/...)** – the emissions requirements do not apply to purely electric vehicles; however, hybrid vehicles (e.g. battery powered vehicles with an internal combustion engine powering an onboard generator) will be expected to comply with the relevant emissions ADRs;
- **Braking Systems (ADRs 31, 31/..., 35x, and 35/...)** – large increases in vehicle mass, alteration of the centre of gravity and/or removal of the normal vacuum or compressed air source will affect compliance with these rules and it is essential that braking performance be maintained within the limits set out by these rules. The addition of a secondary source of vacuum or compressed air will usually be required.

2 TECHNICAL AND SAFETY REQUIREMENTS - ELECTRICAL

2.1 Electrical Definitions

ELV: **Extra Low Voltage.** Any voltage that never exceeds 60V DC or 25V AC. (Typically powering electrical items such as lights, horn, fans, etc.).

HAZV: **Hazardous Voltage.** Any voltage that may be greater than 60V DC or 25V AC at any time. (Typically the voltage of the main traction battery pack or the motor drive circuits).

2.2 Battery Type

There is a significant difference in safety requirements for different types of batteries. For the purposes of this document, batteries are divided into two principal types:

Class A: The batteries do not contain (*spillable*) liquid and do not discharge gases into the atmosphere during normal operation.

Class B: The batteries contain (*spillable*) liquid and/or discharge gas during normal operation.

As a broad classification, lead-acid flooded batteries are Class B, while Nickel Metal Hydride (NiMH) and Lithium batteries are Class A.

2.3 Battery Restraint

The batteries that power the vehicle must be fixed in position so that they will not easily break free in a crash and thus create a hazard to the driver, passengers or other road users. The battery restraint system must adequately withstand at least the following crash accelerations:

Front impact	–	20 g (i.e. 20 times the battery weight);
Side impact	–	15 g;
Rear impact	–	10 g; and
Vertical (rollover) impact	–	10 g.

An impact sensing (*G force*) switch should be fitted to the vehicle so that the traction circuit is opened in the event of an impact.

Battery restraints must be designed so that during fitting and maintenance operations, either the restraints or any tools required cannot easily provide a short circuit path for the battery terminals or other exposed wiring and connections. Similarly, it is recommended that insulated tools are used for fitting or maintenance operations.

2.4 Containment of Batteries

All batteries that must be vented (i.e. Class B batteries) must be fully sealed from the passenger compartment, so that the transmission of gases or flames is prevented. The sealed compartment should be made from corrosion resistant materials, or if this not practical, lined with corrosive resistant materials. Fully sealed (i.e. Class A batteries) need not comply with this section.

Any battery system which is sealed and externally vented, or contains a water replenishing device that connects a number of batteries, must be designed so that propagation of flame between battery cases cannot occur.

All batteries must be enclosed to provide water resistance and exclusion of foreign objects, to a rating of at least IP2X (refer Appendix A - *International Protection (IP Codes)*).

As an additional precaution, a roll-over detection switch should also be considered, especially for vehicles powered by Class B batteries that contain spillable liquid.

2.5 Venting of Battery Compartments (Class B Only)

The design of the batteries, or battery compartments, must provide for venting directly to atmosphere of all gases given off by normal battery operation. This is of utmost importance for lead-acid batteries because hydrogen can be given off in quantities sufficient to cause an explosion during recharging. Inlets and outlets for venting must be well separated to prevent exhausting gases from re-entering the compartment. Venting must not exit underneath the vehicle because accumulation of potentially explosive gasses may occur.

Depending on battery type and the size of the vents, a forced ventilation system may be required.

2.6 Labelling of Battery Compartments

Some batteries contain chemicals, particularly acids, which may cause a hazard in the event of a crash. Each battery compartment should be labelled with the appropriate hazard symbols for the battery chemistry in use.

2.7 Marking of Hazardous Voltage Components

Electric vehicles usually employ higher voltages than normal internal combustion vehicles and consideration needs to be shown to the safety of the end-user of the vehicle, service personnel, and emergency responders in the event of an accident.

Consequently, all components in the vehicle containing a connection to a HAZV battery pack, or which contain HAZV relative to the chassis, must be clearly labelled.

All wiring in the vehicle connected to a HAZV battery pack (either positive or negative), or containing HAZV relative to the chassis of the vehicle, must be coloured orange even when installed within orange conduit. A short length of red or black heat-shrink may be used at the ends of the cables to indicate polarity as necessary. For all new wiring, orange coloured wiring must only be used for HAZV circuits. (Original wiring harnesses fitted by the vehicle manufacturer that contain orange wiring do not need to be modified to remove the orange wiring).

Red and black wiring colours must be reserved for ELV circuits.

2.8 Protection Against Electric Shock

Direct contact with HAZV parts of the vehicle must be prevented either by insulation or by the use of a reliably secured cover that can only be removed with the use of a tool.

In passenger and load compartments of the vehicle, the covers must protect any exposed HAZV components to a protection rating of at least IP4X.

Covers in other areas of the vehicle (including under the bonnet) must protect any exposed HAZV components to a protection rating of at least IP2X.



Figure 1 Warning Labels

Covers protecting HAZV parts must have either one of the two warning labels shown in Figure 1 affixed in a conspicuous location. The label should be at least 40 mm in height unless there is not enough space for a label of this size. Where space is restricted, the largest possible warning label having the same message and characters must be used. (These warning labels are readily available and comply with AS 1319-1994 *Safety signs for the occupational environment*).

All HAZV wiring should be located outside the passenger compartment or load space in order to minimise the possibility of contact by the operator or passengers. In places where the placement of electrical wiring in the passenger compartment or load space is unavoidable, the wiring must be contained within a protective housing such as flexible or rigid orange conduit.

2.9 Hazardous Voltage Isolation

Any HAZV traction battery system must be isolated from the chassis of the vehicle, and also from any auxiliary ELV components and wiring. Isolation must be designed such that there is a leakage current of less than 20 mA between any part of the HAZV system and either the chassis or ELV components in the vehicle, measured when the vehicle is at rest.

This requirement means that both the HAZV battery pack positive, and the HAZV battery pack negative, are to be floating relative to the chassis during normal operation, and both are to be treated as HAZV components.

A ground fault detection circuit or device may be used to identify that either the battery pack positive or battery pack negative have come into contact with the chassis or ELV part of the vehicle, and flag this as a fault to the driver or service technician.

Isolation should be checked manually before commencing any work or repairs on the HAZV circuits and any handbook or information prepared to assist the owner should make reference to this precaution.

2.10 Hazardous Voltage Disconnect

The power on procedure must be applied via a key switch.

It must not be possible to remove this key in any position that energises the drive train or makes active driving possible.

Disconnection of the traction pack from the rest of the traction circuit must be by a contactor operated by the ignition switch.

An inertia switch should be employed to disconnect the traction pack from the rest of the traction circuit in the event of a collision.

Additional switches may be installed to interrupt the supply to assist the user or repairer of the vehicle. For example, a toggle switch may be installed to enable the driver to shut down the battery supply without resorting to turning off the ignition key, as switching off the ignition will also disable devices such as brake boosters and also potentially lock the steering.

The circuit depicted in Figure 2 below depicts one example of how the circuit could be designed.

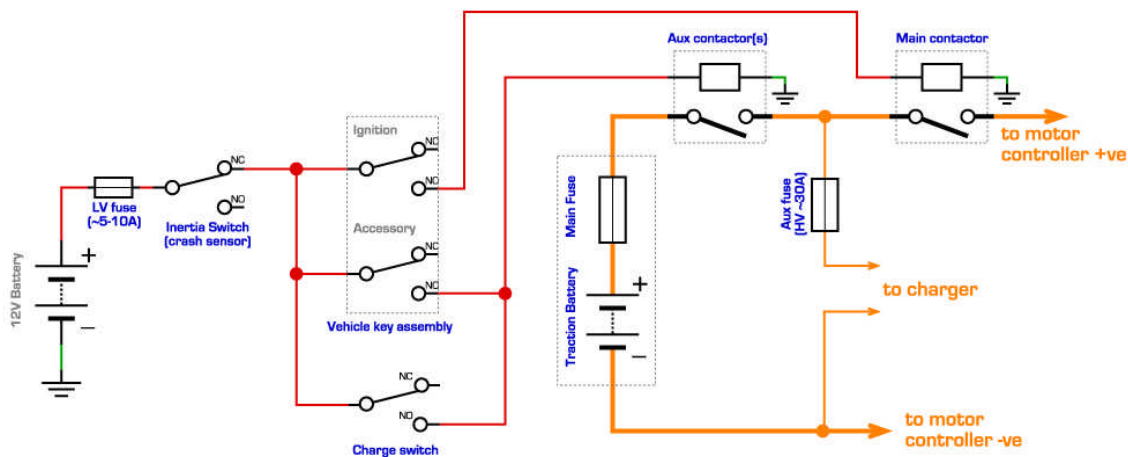

Figure 2 Typical Circuit Showing Ignition Switch, Battery Pack Contactors and Optional HV Disable Switch

2.11 Hazardous Voltage Protection

A battery pack over-current protection device (e.g. fuse or overload relay) must be installed in the traction supply circuit. It should be located with the minimum practical length of cable between the battery terminals and the device, to minimize the chance of a fault occurring in the unprotected section of cable.

Due to the presence of explosive gases, the fuse or other device for a Class B battery pack must be located outside of the battery enclosure unless *EX* (explosion proof) rated. The fuse or other device for a Class A battery pack should be located inside the battery enclosure to help minimise the exposed length of cable.

The over-current protection device must be rated by its manufacturer for use with direct current and at the maximum possible battery voltage. The over-current protection device must have an interrupting rating or breaking capacity which exceeds the maximum possible fault current which may flow – usually the short circuit current of the battery, but possibly the maximum fault current of the traction circuit. If the over-current protection device is a fuse, it should be a high rupture capacity (HRC) type fuse.

2.12 Power Supply Priority

If safety equipment such as lights, brakes and windscreen wipers use the same power source as the traction motor, these services must be supplied in preference to the traction circuit. The design of any ancillary equipment supply should be such that satisfactory operation of all equipment, particularly brakes and headlights, is available throughout the discharge cycle of the traction batteries.

2.12.1 Auxiliary ELV

An independent auxiliary ELV (nominally 12V) must be used to guarantee the supply of power to safety equipment such as lights, brake boosters and windscreen wipers in the event of a shutdown of the main battery system in the vehicle. (Typically this power supply is a 12V battery).

The auxiliary supply must be capable of operating the hazard lights (four-way flashers) at normal duty cycle, for a minimum period of 20 continuous minutes.

If the auxiliary supply is charged via a DC/DC converter from the main traction battery pack, then it must be supplied in preference to the traction circuit, i.e. the motor should stop working before the headlights. The auxiliary equipment supply must be designed so that the satisfactory operation of all equipment, particularly brakes and headlights, is possible throughout the discharge cycle of the traction batteries.

2.13 Vehicle Directional Control

Vehicles not fitted with a conventional gearbox and using a voltage reversal switch to select reverse drive must be designed so that they cannot be accidentally placed in reverse. This action requires either:

- a) A combination of two different actuations, e.g. a toggle switch with a cover, or a separate reverse enabling switch; or
- b) A momentary contact switch which allows reverse gear to be engaged only when the vehicle is moving with a forward speed of less than 5 km/h. Above this speed all actions on this switch must be ineffective.

The state of the drive direction (e.g. forward/neutral/reverse) must be readily identifiable to the driver. This can be achieved by a number of means including labels on or near the direction control device, lamps on the dash etc..

The vehicle must not be capable of being driven in either direction if the ignition key switch is not in the *On* position. The drive motor controller or other device software may be utilised to achieve this requirement.

It must not be possible to remove the ignition key from any switch position that energises the drive train or makes active driving possible.

The vehicle must not be capable of being driven in either direction if the vehicle is connected to an energy supply network or an off-board charger.

2.14 Battery Management

For series strings of batteries, some form of charge or balance management should be implemented. The necessity of this requirement will be dependent on the battery chemistry and technology used in the vehicle.

This is especially critical with lithium chemistry batteries which must be maintained within strict upper and lower voltage limits and upper temperature limits. Some form of device to monitor these limits *on each individual cell or group of parallel cells* should be present.

If a monitoring device is fitted, the monitoring device must be capable, of either audibly or visually by means of a flashing lamp, warning the driver of an impending disconnect with sufficient time for the driver to safely park the vehicle before disconnection occurs.

2.15 Allowance for Australian Climatic Conditions

To ensure satisfactory service over the range of climatic conditions found in Australia, electric vehicles should be designed for prolonged operation at ambient temperatures ranging from -10°C to +50°C.

3 TECHNICAL AND SAFETY REQUIREMENTS - MECHANICAL

3.1 Changes to Vehicle Mass and Load Carrying Capacity

Following an electric vehicle conversion there is a strong likelihood that certain mechanical components of the vehicle will become overloaded because of the increase in mass caused by the addition of the traction batteries and motors. The load carrying capacity of tyres, suspension and axles of converted passenger cars and light commercial vehicles are the most likely components to be affected by the conversion. In these cases, the affected components must be changed or modified to safely carry the applied loads.

The strength and fatigue resistance of every component must also be checked to ensure it is adequate for its new function.

The final mass distribution of the vehicle must be checked as components can be overloaded without an increase in total mass.

In many cases the installation of upgraded tyres or springs will be sufficient. However in more complex cases, the assistance of a suitably qualified signatory or engineer will be required to ensure the vehicle can safely carry the applied loads.

In assessing the total mass and mass distribution allow at least 68 kg per passenger, plus 13.6 kg of luggage for each passenger, for a total minimum allowance of 81.6 kg per passenger.

This allowance is the legal minimum. Given the size of the Australian population, it is recommended that the allowance used is higher. The intended use of the vehicle should also be considered – a vehicle intended for shopping or as a family runabout will require a higher allowance than a vehicle used purely for commuting.

Mass distribution should be as low and centrally located as possible in the vehicle to assist with vehicle stability.

After the vehicle conversion is completed, contact the Registration Authority in which the vehicle is registered (or about to be registered) to determine what the obligations are with respect to notification about changes in vehicle mass. It will be necessary to have the completed vehicle weighed in its unladen state to determine its *unladen mass* or *tare*.

Table 2 provides a guide to the information required for various vehicle types.

This information will need to be submitted together with a weigh certificate acceptable to the Registration Authority.

Table 2: Reporting Requirements for Changes to Vehicle Mass

Vehicle Status	Information Required by Registration Authorities
For an unregistered ICV (passenger car) (ADR category MA, MB and MC)	Unladen mass or tare.
For an unregistered goods carrying ICV (ADR category NA, NB)	Tare and a designated Gross Vehicle Mass (GVM). If the vehicle is intended to tow another vehicle, its designated Gross Combination Mass (GCM) also.
For a modified passenger vehicle (ADR category MA, MB and MC)	The new tare.
For a modified goods carrying vehicle (ADR category NA, NB)	The new tare and new GVM if applicable. If the vehicle is intended to tow another vehicle, its designated GCM also.

3.2 Brakes and Steering

If the vehicle is a new ICV it must be constructed to comply with the applicable braking ADRs for the category of vehicle and its date of manufacture. Refer to Section LO for mandatory requirements.

If the vehicle is modified it must continue to comply with the applicable braking ADRs for the category of vehicle and its date of manufacture. Refer to Section LO for applicable ADRs and Section LG *Brakes* for brake modification allowed under the provisions of VSB 14.

If the original vehicle was fitted with air brakes, vacuum assisted brakes or power assisted steering, an alternative source of energy must be fitted. The power and capacity of the new source must be of sufficient capacity to provide efficient functioning of the system and meet all the legal capacity requirements.

The vehicle must continue to comply with the design rule requirement that vehicles have a brake failure-warning lamp that can be tested by turning the ignition switch to a point that energizes the

system. If a fault in the braking system is detected, the warning lamp must remain illuminated when the vehicle is either stationary or moving. The intensity of the warning lamp must be of a sufficient level to allow the driver to see the lamp operating in daylight.

Vacuum assisted braking systems should be provided with audible or visual low vacuum warning devices.

Regenerative braking, if used, should not alter the balance between front and rear braking characteristics of the original vehicle. As a general guideline, regenerative braking should not exceed the deceleration levels generated by the original internal combustion engine and must never disconnect the friction braking system.

Service braking systems that are modified to include regenerative braking as part of the service braking system are not covered by these Guidelines and advice must be sought from the relevant Registration Authority if this type of modification is contemplated. Similarly, advice must be sought from the relevant Registration Authority if an ICV is to be designed to have regenerative braking incorporated in the service braking system. (For the purposes of these Guidelines, activation of regenerative braking by either lightly touching or applying pressure on the brake pedal means that regenerative braking is part of the service brake system and therefore not covered by these Guidelines).

Because mass distribution is an important factor in maintaining good handling and braking characteristics of a vehicle, it must be considered carefully in the design of a conversion or ICV. For example, a significant reduction of front axle mass may lead to poor cornering behaviour as a result of loss of traction together with deterioration in braking performance.

Care should therefore be taken to minimise changes in mass distribution. Where this is unavoidable, brake bias must be adjusted to take into account the changes in mass distribution.

Locating the battery pack entirely behind the rear axle should be avoided as it may lighten steering and/or cause the vehicle to yaw in a dangerous manner, particularly if the vehicle has a relatively large rear overhang. Vehicles with front wheel drive may also lose drive traction. Vehicles displaying any of the above undesirable characteristics will be rejected by Registration Authorities.

Any alterations or modifications to steering must comply with Section LS *Tyres, Rims, Suspension and Steering*.

3.3 Body or Chassis Modifications

Major body or chassis modifications to existing vehicles must be supported by an engineering report.

Certain body or chassis modifications are covered by Section LH *Body and Chassis* of VSB 14. Modifications of this type must comply with the appropriate modification codes specified in Section LH.

Unless supported by an engineering report provided by a suitably qualified signatory, electrical components such as electric motors must not be used in place of structural members or to perform structural functions. Gearboxes and other heavy components must be independently supported by suitably designed brackets or members.

3.4 Fuel System Modifications

Section LM *Fuel Systems* of VSB 14 covers modifications to fuel circuits, fuel tanks, fuel lines and fuel pumps. Section LM must be referenced and followed if it is intended to keep the internal combustion engine as an alternative power source and it is necessary to modify the fuel

system as a result. The vehicle must continue to comply with the emission ADRs applicable to the vehicle when it was first ready for registration.

4 OTHER ISSUES

4.1 Pedestrian Safety

As electric vehicles are normally much quieter than vehicles powered by internal combustion engines, the safety of pedestrians should also be given consideration.

People with hearing difficulties and/or limited vision are often not aware of the existence of very quiet vehicles in their vicinity and as a consequence feel very vulnerable in the knowledge that the number of these vehicles is increasing.

The installation of closed circuit televisions, proximity sensors or reversing alarms may assist in reducing the likelihood of an accident in the above circumstances.

4.2 Protection of Onboard Appliances

All onboard appliances such as DC converters, heater demisters, air conditioning etc. using traction pack voltages must be protected from current overload by the use of appropriate fuses or circuit breakers.

4.3 Electrical Installation Standards

All electrical installation work must be designed and executed in accordance with acceptable codes and standards. Before starting construction of an electric vehicle, some knowledge can be gained by reading Australian/New Zealand Standard AS/NZS 3000:2000: *Electrical installations* (known as the Australian/New Zealand Wiring Rules), in particular, section 7.9 *Hazardous Areas*.

All external HAZV wiring must be effectively secured to the chassis at regular intervals of not more than 600mm, unless supported by a conduit or other rigid protective housing. The wiring must be kept away from moving and hot parts and be protected from chafing against sharp edges.

It is important to ensure that the size and insulation of the cable used in the traction circuit is suitable for its intended application. Most automotive cable is not designed for the higher voltages used in electric vehicles or for constant high current operations. Allowances should be made for high peak currents in the stall and heavy acceleration modes.

4.4 Alternative Standard

The electrical system of a vehicle will be acceptable if it can be shown to comply with the technical requirements of UN ECE Regulation N^o 100 *Uniform Provisions Concerning the Approval of Battery Electric Vehicles with Regard to Specific Requirements for the Construction and Functional Safety*. It must be noted that such a vehicle is still required to comply with all of the ADRs that may be affected by the conversion.

4.5 Radio Frequency (RF) Remote Controls

The Australian Communications and Media Authority (ACMA) is the body responsible for administering the laws relating to electromagnetic and radiofrequency emissions.

Builders or modifiers must ensure that any RF devices they manufacture or use are in compliance with the ACMA requirements and are appropriately labelled.

More information is available from the Authority or its website:

www.acma.gov.au.

DRAFT

Appendix A - International Protection (IP Codes)

The **IP Code** defined in international standard IEC 60529 classifies the degrees of protection provided against the intrusion of solid objects (including body parts like hands and fingers), dust, accidental contact, and water in electrical enclosures. It consists of the letters IP (for *International Protection* or *Ingress Protection*) followed by two digits and an optional letter. The two digits provide measures of the degree of protection the enclosure provides – the first against a solid object gaining access from the outside and for the second digit, for the degree of protection against water. The standard aims to provide users with more detailed information than vague marketing terms such as *waterproof*.

Where there is no protection rating with regard to one of the criteria, the digit is replaced with the letter **X**.

For example, an electrical socket rated IP22 is protected against insertion of fingers and will not be damaged or become unsafe during a specified test in which it is exposed to vertically or nearly vertically dripping water. IP22 or IP2X are typical minimum requirements for the design of electrical accessories for indoor use.

More Information is available at the *International Electrotechnical Commission* website:

<http://www.iec.ch/>

Checklist LV1 CODE LV1 Electrical Power Installation Checklist

Owner Details

Owner's Name _____

Address _____

Telephone _____ Mobile _____

Email _____

Vehicle Details

Make _____ Model _____ Year of Manufacture _____

Vehicle Mass (kg) _____ Fuel Tank Certification Number (where applicable) _____

VIN/Chassis Number _____

[Continued overleaf]

Motive Power Source

Does the vehicle have a hybrid power source? Y N NA

If Yes:

Briefly describe the hybrid type _____

Electric Motor Details

Make _____ Type _____
Continuous Power Output _____ kW
Year of manufacture _____

Combustion Engine Details if Applicable

Make _____ Type _____ No. of Cylinders/Rotors _____
Displacement _____ Litres or _____ Cubic Inches Year of Manufacture _____
ADR Engine was designed to comply with _____ Maximum Power Output _____ kW or _____ BHP

Signatory Certification

Vehicle Certified By (Signatory) _____
Signatory Employer (if applicable) _____
Signatory's Signature _____ Date _____

[Continued overleaf]

(NA=Not Applicable, Y=Yes, N=No)

Clause	Feature	Compliance
1.1	Has this vehicle, other than the electric drive and controls, been built to comply with the provisions of VSB 14 Section LO for the type and category of ICV that applies to this vehicle?	Y <input type="checkbox"/> N <input type="checkbox"/> NA <input type="checkbox"/>
1.1	Are all ICV checklists completed and signed?	Y <input type="checkbox"/> N <input type="checkbox"/> NA <input type="checkbox"/>
Clause	Feature	Compliance
1.2	Have all modifications been carried out in accordance with the appropriate Sections of VSB 14?	Y <input type="checkbox"/> N <input type="checkbox"/> NA <input type="checkbox"/>
1.2	Are all modification checklists completed and signed?	Y <input type="checkbox"/> N <input type="checkbox"/> NA <input type="checkbox"/>
Clause	Feature	Compliance
2.3	Are the batteries restrained to cope with the specified forces?	Y <input type="checkbox"/> N <input type="checkbox"/> NA <input type="checkbox"/>
Clause	Feature	Compliance
2.4	Are batteries properly sealed so that escaping gases or fluid cannot enter the vehicle cabin?	Y <input type="checkbox"/> N <input type="checkbox"/> NA <input type="checkbox"/>
2.4	Except for ventilation are all exterior battery compartment openings fully sealed?	Y <input type="checkbox"/> N <input type="checkbox"/> NA <input type="checkbox"/>
2.4	Has the potential for flame propagation between battery cases been minimised?	Y <input type="checkbox"/> N <input type="checkbox"/> NA <input type="checkbox"/>
Clause	Feature	Compliance
2.5	Are battery compartments properly vented? (Class B only)	Y <input type="checkbox"/> N <input type="checkbox"/> NA <input type="checkbox"/>
2.5	If forced ventilation is required is it designed to:	
	Minimise the risk of ignition?	Y <input type="checkbox"/> N <input type="checkbox"/> NA <input type="checkbox"/>
	Operate automatically?	Y <input type="checkbox"/> N <input type="checkbox"/> NA <input type="checkbox"/>
	Extract the gases? (i.e. by not blowing air into the compartments).	Y <input type="checkbox"/> N <input type="checkbox"/> NA <input type="checkbox"/>
	Have a greater air flow capacity than the rate at which gases form?	Y <input type="checkbox"/> N <input type="checkbox"/> NA <input type="checkbox"/>
	Have sufficient capacity to keep the batteries at an acceptable temperature?	Y <input type="checkbox"/> N <input type="checkbox"/> NA <input type="checkbox"/>
2.5	Are there no inlet or outlet openings located underneath the vehicle?	Y <input type="checkbox"/> N <input type="checkbox"/> NA <input type="checkbox"/>

[Continued overleaf]

(NA=Not Applicable, Y=Yes, N=No)

2.5	Are all Inlet and outlet openings well separated?	Y <input type="checkbox"/> N <input type="checkbox"/> NA <input type="checkbox"/>
Clause	Feature	Compliance
2.6	Are battery compartments labelled with the appropriate hazard symbols?	Y <input type="checkbox"/> N <input type="checkbox"/> NA <input type="checkbox"/>
Clause	Feature	Compliance
2.7	Is all HAZV wiring and conduit carry HAZV wiring coloured orange?	Y <input type="checkbox"/> N <input type="checkbox"/> NA <input type="checkbox"/>
2.7	Are all HAZV components clearly labelled?	Y <input type="checkbox"/> N <input type="checkbox"/> NA <input type="checkbox"/>
Clause	Feature	Compliance
2.8	Are all HAZV parts adequately insulated or protected to prevent accidental direct contact with those parts?	Y <input type="checkbox"/> N <input type="checkbox"/> NA <input type="checkbox"/>
2.8	Is a protection rating of at least IP4X provided for any exposed HAZV components inside the passenger compartment of the vehicle?	Y <input type="checkbox"/> N <input type="checkbox"/> NA <input type="checkbox"/>
2.8	Is a protection rating of at least IP2X provided for any exposed HAZV components elsewhere on the vehicle?	Y <input type="checkbox"/> N <input type="checkbox"/> NA <input type="checkbox"/>
2.8	Are all covers protecting HAZV components suitably labelled?	Y <input type="checkbox"/> N <input type="checkbox"/> NA <input type="checkbox"/>
2.8	Is all HAZV wiring suitably located and protected against damage?	Y <input type="checkbox"/> N <input type="checkbox"/> NA <input type="checkbox"/>
Clause	Feature	Compliance
2.9	Is the HAZV traction battery system adequately isolated from the vehicle chassis so that leakage current does not exceed 20 mA?	Y <input type="checkbox"/> N <input type="checkbox"/> NA <input type="checkbox"/>
Clause	Feature	Compliance
2.10	Is the traction power disconnect switch operated by the ignition switch?	Y <input type="checkbox"/> N <input type="checkbox"/> NA <input type="checkbox"/>
2.10	Is an inertia switch fitted to disconnect power in the case of a front-on crash?	Y <input type="checkbox"/> N <input type="checkbox"/> NA <input type="checkbox"/>
Clause	Feature	Compliance
2.11	Is a battery pack over-current protection device fitted?	Y <input type="checkbox"/> N <input type="checkbox"/> NA <input type="checkbox"/>
2.11	Is the minimum amount of cabling used between the device and the battery terminals?	Y <input type="checkbox"/> N <input type="checkbox"/> NA <input type="checkbox"/>

[Continued overleaf]

(NA=Not Applicable, Y=Yes, N=No)

Clause	Feature	Compliance
2.12	Is an auxiliary ELV provided to ensure safety equipment such as brakes and lamps receive priority for power supply?	Y <input type="checkbox"/> N <input type="checkbox"/> NA <input type="checkbox"/>
2.12	Does the auxiliary ELV have sufficient capacity to operate the hazard warning lamps for at least 20 continuous minutes?	Y <input type="checkbox"/> N <input type="checkbox"/> NA <input type="checkbox"/>
Clause	Feature	Compliance
2.13	If not fitted with a conventional gearbox is there a device which prevents the vehicle accidentally being driven in reverse?	Y <input type="checkbox"/> N <input type="checkbox"/> NA <input type="checkbox"/>
2.13	Is the state of the drive direction readily identifiable to the driver?	Y <input type="checkbox"/> N <input type="checkbox"/> NA <input type="checkbox"/>
2.13	Is the motor prevented from operating in either direction if the ignition switch is not in the on position?	Y <input type="checkbox"/> N <input type="checkbox"/> NA <input type="checkbox"/>
2.13	Is it not possible to remove the ignition key in any position that energises the drive train or makes active driving possible?	Y <input type="checkbox"/> N <input type="checkbox"/> NA <input type="checkbox"/>
2.13	Is the vehicle not capable of being driven in either direction if the vehicle is connected to an energy supply network or an off-board charger?	Y <input type="checkbox"/> N <input type="checkbox"/> NA <input type="checkbox"/>
Clause	Feature	Compliance
3.1	Is the vehicle structure, including tyres, of sufficient capacity to carry the completed vehicle and its expected load?	Y <input type="checkbox"/> N <input type="checkbox"/> NA <input type="checkbox"/>
3.1	Have all individual components been checked for load capacity?	Y <input type="checkbox"/> N <input type="checkbox"/> NA <input type="checkbox"/>
3.1	Has the vehicle been weighed and all information relating to changes in vehicle mass or carrying capacity been recorded for forwarding to the Registration Authority?	Y <input type="checkbox"/> N <input type="checkbox"/> NA <input type="checkbox"/>
Clause	Feature	Compliance
3.2	Have brakes and steering been checked and found to comply with the appropriate requirements as specified in Sections LG and LS of VSB 14?	Y <input type="checkbox"/> N <input type="checkbox"/> NA <input type="checkbox"/>

[Continued overleaf]

(NA=Not Applicable, Y=Yes, N=No)

3.2	Have all the appropriate checklists for the Section LG and LS codes been completed and submitted as required by the Registration Authority?	Y <input type="checkbox"/> N <input type="checkbox"/> NA <input type="checkbox"/>
Clause	Feature	Compliance
3.3	Unless supported by an engineering report, are there no electrical components being used as structural components?	Y <input type="checkbox"/> N <input type="checkbox"/> NA <input type="checkbox"/>
3.3	Are all chassis or body modifications performed to the appropriate Section LH Codes of VSB 14?	Y <input type="checkbox"/> N <input type="checkbox"/> NA <input type="checkbox"/>
3.3	Have all the appropriate checklists for the Section LH Codes been completed and submitted as required by the Registration Authority?	Y <input type="checkbox"/> N <input type="checkbox"/> NA <input type="checkbox"/>
Clause	Feature	Compliance
3.4	Are all fuel system modifications performed to the appropriate Section LM Codes of VSB 14?	Y <input type="checkbox"/> N <input type="checkbox"/> NA <input type="checkbox"/>
3.4	Have all the appropriate checklists for the Section LM codes been completed and submitted as required by the Registration Authority?	Y <input type="checkbox"/> N <input type="checkbox"/> NA <input type="checkbox"/>
Clause	Feature	Compliance
4.3	Has all electrical work been carried out to an acceptable standard? (Quote Std.....).	Y <input type="checkbox"/> N <input type="checkbox"/> NA <input type="checkbox"/>
4.3	Are all power connections properly insulated?	Y <input type="checkbox"/> N <input type="checkbox"/> NA <input type="checkbox"/>
4.3	Are all cables running through passenger compartments or load spaces properly contained within rigid protective housings?	Y <input type="checkbox"/> N <input type="checkbox"/> NA <input type="checkbox"/>
4.3	Are all cables not contained in a housing or conduit supported at not less than 600mm intervals?	Y <input type="checkbox"/> N <input type="checkbox"/> NA <input type="checkbox"/>
4.3	Have all cables been designed to ensure they have both the capacity and insulation properties to handle the expected high peak currents?	Y <input type="checkbox"/> N <input type="checkbox"/> NA <input type="checkbox"/>
4.3	Are all electrical controls designed on a fail-safe basis?	Y <input type="checkbox"/> N <input type="checkbox"/> NA <input type="checkbox"/>
4.3	Are all fuses and/or overload relays located in the appropriate section of the vehicle?	Y <input type="checkbox"/> N <input type="checkbox"/> NA <input type="checkbox"/>
4.3	Are all electrical components used in DC circuits rated for DC use?	Y <input type="checkbox"/> N <input type="checkbox"/> NA <input type="checkbox"/>
Clause	Feature	Compliance
4.4	Do all RF devices comply with ACMA requirements and are they appropriately labelled?	Y <input type="checkbox"/> N <input type="checkbox"/> NA <input type="checkbox"/>