

# **Vehicle Standards Bulletin 14**

**NATIONAL CODE OF PRACTICE  
for  
LIGHT VEHICLE CONSTRUCTION  
and  
MODIFICATION**

**NATIONAL GUIDELINES for  
INDIVIDUALLY CONSTRUCTED  
LE1 MOTOR TRICYCLES  
(OTHER THAN GOODS VEHICLES)  
in AUSTRALIA**

**Version 2.0 December 2009**

## Vehicle Standards Bulletin 14

### National Code of Practice for Light Vehicle Construction and Modification (VSB 14)

#### INDIVIDUALLY CONSTRUCTED VEHICLE (ICV) GUIDELINES FOR LE1 MOTOR TRICYCLES

##### **Important Information for Users**

This document needs to be used in conjunction with the appropriate administrative requirements of the jurisdiction in which the vehicle is to be registered. *Administrative requirements* include, amongst other things, processes for vehicle registration, obtaining exemptions, obtaining modification approvals, vehicle inspections, preparation and submission of reports and the payment of appropriate fees and charges.

If unsure of any of these requirements, or if more information is needed for any other issue or processes, users should contact the relevant Registration Authority **prior** to commencing any work.

While these Guidelines present a great deal of information with respect to the construction of *trikes*, it is nonetheless important that builders make themselves familiar with the content of VSB 14.

Users of the Guidelines and VSB 14 also need to ensure that they refer to the most recent version of the relevant Section/s when working on a project. The version is identified by the version number and date on the face page of each Section. The version and date is also located in the footer of each page in each Section. On the website the version number is specified in the Section file name for easy identification.

If a project is taking a long time to complete, check the currency of the version you are using.

Users must be familiar with the provisions stated in the Preface and Introduction. These two Sections provide the necessary background information to assist users in understanding how VSB 14 is administered by Registration Authorities across Australia, on how it is structured, and the meaning of the types of modification codes specified in VSB 14. If not already done so, users should download them for study and reference.

Understanding these requirements is important to ensure that the correct processes are followed thereby reducing the likelihood of having work rejected by Registration Authorities.

Many of the Sections refer to other Sections within VSB 14 for further information or additional requirements. Users must read and apply all relevant Sections.

If in doubt about any issue concerning or contained in these Guidelines or VSB 14, users should seek clarification from the appropriate State or Territory Registration Authority.

**Please do not contact Vehicle Safety Standards (VSS) of the Federal Department of Infrastructure, Transport, Regional Development and Local Government in Canberra about VSB 14. VSS provides the website as a service only.**

## CONTENTS

	<b>Preface</b>	<b>5</b>
<b>1</b>	<b>ADR-Motor Tricycle Classifications</b>	<b>9</b>
<b>2</b>	<b>Technical and Safety Requirements</b>	<b>11</b>
	2.1 Frames	11
	2.2 Fasteners	12
	2.3 Stability Compliance Testing	13
	2.4 Engines	13
	2.5 Exhaust Systems	13
	2.6 Brakes	13
	2.7 Front Suspension	14
	2.8 Rear Suspension	17
	2.9 Ground Clearance	20
	2.10 Rims and Tyres	20
	2.11 Maximum Width	21
	2.12 Fuel Systems	21
	2.13 Seating and Seatbelts	21
	2.14 Handlebars	21
	2.15 Mudguards	22
	2.16 Drive Shafts, Chains and Belts	22
	2.17 Electrical	22
	2.18 Instrumentation	24
	2.19 Reverse Gear	24
	2.20 Certified Vehicle Mass	24
	2.21 Immobilisers	24
	2.22 Vehicle Condition	24

<b>3</b>	<b>Compliance with Redundant Australian Design Rules</b>	<b>25</b>
<b>4</b>	<b>Appendices</b>	<b>26</b>
1	ADR 42/04 Stability Test Report and Explanatory Diagrams	26
2	Summary of Applicable Australian Design Rules	30
3	Seatbelt Mounting Examples	37
4	Checklists	38

## PREFACE

### BACKGROUND

This document was originally prepared in consultation with the WA Trike Construction Working Group.

These Guidelines have subsequently been endorsed by all Australian State and Territory Jurisdictions responsible for vehicle standards and the registration of vehicles for road use.

These Guidelines apply to the construction of Motor Tricycles, hereafter referred to as *trikes*.

### TERMS AND REFERENCES

Within these Guidelines the following terms have the following meanings.

<b>May:</b>	Indicates an option.
<b>Should:</b>	Indicates a recommendation.
<b>Must:</b>	Indicates mandatory.

Unless otherwise specified, **certification** in this document means **certification** to the requirements specified within VSB 14 and these Guidelines.

*Signatory* is a person who is accredited to, or registered with a Registration Authority for assessing and certifying modified vehicles for the purposes of registration.

(For the purposes of VSB 14 and its Guidelines, the term *Signatory* applies to engineers and tradespersons involved in the approval process. Wherever the term *Signatory* is used, it implies that the *Signatory* referred to is one who has the necessary qualifications and experience to assess and sign-off the matter under consideration).

All notes, diagrams, tables, headings and examples included in VSB 14 and in these Guidelines form part of VSB 14 and these Guidelines respectively.

### SCOPE

These Guidelines are applicable to LEM1 and motor cycle type LEP1 *trikes*. LEM1 and LEP1 categories are defined in the Australian Design Rules (ADRs).

These Guidelines do not cover the construction of LEG vehicles (goods vehicles), *passenger car type* LEP1 vehicles or LEM2 and LEP2 vehicles (*Morgan type trikes*). These vehicles will continue to be dealt with on an individual basis by the jurisdiction in which the *trike* is built.

These Guidelines form an integral part of the Vehicle Standards Bulletin *National Code of Practice for Light Vehicle Construction and Modification* (VSB 14). Section LO *Vehicle Standards Compliance* of VSB 14 outlines the minimum requirements for the assessment and certification of compliance with the ADRs for individually constructed vehicles. VSB 14 provides codes under which modifications or vehicle construction can be shown to be in conformity with the ADRs. Code LO4 applies to LEM1 *trikes* while Code LO5 applies to LEP1 *trikes*.

The checklists for LO4 and LO5 are contained in these Guidelines.

While these Guidelines present a great deal of information with respect to the construction of *trikes*, builders must make themselves familiar with the content of VSB 14 and apply any relevant requirements.

These Guidelines do not cover vehicle registration policies or procedures, nor do they cover the technical requirements for *trikes* that must be certified under the provisions of the Federal Motor Vehicle Standards Act.

### INTENT AND PURPOSE

These Guidelines are intended to provide a nationally uniform set of technical specifications that ensure *trikes* built in accordance with these Guidelines comply with the applicable requirements of the *Third Edition Australian Design Rules* and the *Australian Vehicle Standards Rules 1999 (AVSR)*.

These Guidelines are for the assistance of those who intend to manufacture an Individually Constructed Vehicle (ICV) in the form of a *trike*. Their ultimate aim is to ensure that each completed vehicle is safe for use on the road.

### RELATIONSHIP WITH THE LAWS OF AUSTRALIAN JURISDICTIONS

Subject to Federal laws and the laws of the States and Territories of Australia, this document defines standards of practice for the design, manufacture and modification of *trikes*. Other procedures are acceptable subject to adequate technical justification.

Nothing in these Guidelines is to be regarded as in any way limiting the powers and duties of the Minister, Chief Executive Officer of the Registration Authority in question, or any agent or employee of that Officer, under the appropriate Act/s of that jurisdiction, or subsidiary legislation made thereunder.

Where any ADR or any Australian Vehicle Standards Rule is referred to in these guidelines, the appropriate Australian Design Rule or Australian Vehicle Standards Rule should be read in full to avoid misinterpretation.

Each jurisdiction may have different clause numbers in its adopted version of the AVSR.

Vehicle owners or builders must seek advice from the appropriate jurisdiction if in doubt about any of the above issues.

### ADMINISTRATION

These Guidelines provide a set of uniform technical specifications for the construction and modification of *trikes* that can be used across Australia. Jurisdictions have their own administrative procedures and requirements for the registration of new vehicles and for the approval of modifications. Owners and registered operators must familiarise themselves with the provisions of the jurisdiction in which they reside. Similarly, owners or registered operators of *trikes* who wish to transfer their vehicle registration to another state or territory need to obtain relevant information from the jurisdiction in which the vehicle is to be garaged and registered.

### VSB 14 Codes

*Trikes* built to these Guidelines qualify under Code LO4 and LO5 of VSB 14. Persons authorised under an authorised modification scheme, operated by a jurisdiction, may stamp these codes on the modification plate. The plate specifications, stamping and fixing must be in accordance with the jurisdiction's business rules for the scheme in question.

Persons not authorised to attach modification plates to a vehicle must also use these codes when submitting applications to their local Registration Authority. In all cases the checklists

must be completed. Authorised persons must hold the checklists for auditing purposes, while non-authorised persons must submit the signed-off check lists with their final documentation.

Please refer to your Registration Authority's business rules for more detailed information about the management of checklists.

## FUTURE DEVELOPMENTS

This document needs to be recognised as being a *live document* and hence will need to be revised from time to time to include future developments arising from regulatory changes, improvements in technology and the development of alternative designs.

The document may also be revised to improve its editorial content.

## FUTURE REVISIONS

Future revisions are the responsibility of the Australian Motor Vehicle Certification Board Working Party. Revisions, other than those of a legal or editorial nature, will be processed in consultation with the appropriate user groups.

The Working Party may consider applications from individuals concerning recommended revisions to the Guidelines. However, it is preferable that applications are submitted after consideration by the appropriate user groups. In any event, the Working Party will consult widely before making a final decision on any proposed amendments to the Guidelines.

## DATE AT WHICH THE DOCUMENT TAKES EFFECT

This document takes effect at the date of issue.

## DOCUMENT FORMAT

This document is also available in electronic format and is available for download from the Department of Infrastructure, Transport, Regional Development and Local Government website located at:

[www.infrastructure.gov.au](http://www.infrastructure.gov.au)

Sections of VSB 14 may also be downloaded from the same website. While VSB 14 may be downloaded in sections for the convenience of persons who may have a specific issue to address, any referenced Sections of VSB 14 that are applicable to the work being undertaken under these Guidelines must be read and applied also.

## REVISION HISTORY

Revision	Comments
First Published	This document was approved in principle at the AMVCB Working Party meeting held on the 28th November 2005 and finally accepted, subject to a number of corrections, at a teleconference held on the 17th January 2006.
Second Edition	This document was approved at the AMVCB Working Party meeting held on xxx  The Third Edition ADR applicability list now highlights the ADRs that have been repealed and/or superseded.

	Appendix on welding has been removed and reference made to Section LZ <i>Appendices</i> .
--	---

**Note:** Compliance with these Guidelines does not guarantee that a *trike* will be registered by a Jurisdiction. If, for example, a *trike* does not handle or brake satisfactorily or has any other feature which renders the vehicle unsafe or not roadworthy, it may not be registered. Further, changes to relevant legislation may mean that a *trike* cannot be registered without appropriate modifications.

While these Guidelines present a great deal of information with respect to the construction of *trikes*, builders and registered owners must make themselves familiar with the content of VSB 14.

## ACKNOWLEDGMENTS

This document has been adopted by the Australian Motor Vehicle Certification Board Working Party (AMVCB WP) as the nationally accepted Guidelines for the construction and modification of *trikes* in Australia. These Guidelines form an integral part of the Vehicle Standards Bulletin 14 *National Code of Practice for Light Vehicle Modification and Construction* (VSB 14). The *National Code of Practice* is a major project currently being undertaken by the AMVCB WP.

- The AMVCB WP wishes to acknowledge the key role played by the WA Trike Construction Working Group, and
- Mr M Winter from Wintercreative for the diagrams used in this document.

The project was managed by Mr John Dombrose on behalf of the AMVCB WP as an integral part of the *National Code of Practice for Light Vehicles Construction and Modification*.

Members of the AMVCB WP at the time of Publication include:

- Barry Hendry      National Road Transport Commission
- Dr Gray Scott      VicRoads
- Harry Vertsonis      RTA NSW
- Rod Paule      DUS ACT
- Roland Earl      Transport SA
- Robert Gibson      Queensland Transport
- Simon Saunders      DIPE NT
- Tony Beard      DIER Tas
- John Dombrose      DPI WA

Previous members who assisted in the development of this project included Mr Jorge Montano (RTA NSW), Mr Rickman Smith (Transport SA) and Mr Angus Draheim (Transport QLD).

## 1 ADR MOTOR TRICYCLE CLASSIFICATIONS

Motor Tricycles, to which these Guidelines apply, are defined in the ADRs as follows:

*Motor Tricycle (LE):* A motor vehicle with 3 wheels symmetrically arranged in relation to the longitudinal axis, with a *Gross Vehicle Mass* not exceeding 1.0 tonne, and either an engine cylinder capacity exceeding 50 ml or a *Maximum Motor cycle Speed* exceeding 50 km/h.

LE vehicles are further categorised as follows:

Sub-category

- |      |   |  |
|------|---|--|
| LE1  | - | one wheel at front, 2 at rear.   |
| LE2  | - | 2 wheels at front, one at rear.  |
| LEM1 | - | up to 450 kg <i>Unladen Mass</i> and   |
|      | - | the driver's <i>Seat</i> is of a saddle type and                                 |
|      | - | one wheel at the front, 2 at rear.   |
| LEM2 | - | up to 450 kg <i>Unladen Mass</i> and   |
|      | - | the driver's <i>Seat</i> is of a saddle type and                                 |
|      | - | 2 wheels at front, one at rear.  |
| LEP1 | - | over 450 kg <i>Unladen Mass</i> and/or   |
|      | - | the driver's <i>Seat</i> is not of a saddle type and/or                          |
|      | - | has more than two seating positions and/or                                       |
|      | - | has a permanent structure to the rear of and                                     |
|      | - | 200mm above the undeformed upper surface of the driver's <i>Seat</i> cushion and |
|      | - | one wheel at the front, 2 at rear.   |
| LEP2 | - | over 450 kg <i>Unladen Mass</i> and/or   |
|      | - | the driver's <i>Seat</i> is not of a saddle type and/or                          |
|      | - | has more than two seating positions and/or                                       |
|      | - | has a permanent structure to the rear of and                                     |
|      | - | 200mm above the undeformed upper surface of the driver's <i>Seat</i> cushion and |
|      | - | 2 wheels at front, one at rear.  |
| LEG1 | - | over 450 kg <i>Unladen Mass</i> and  |
|      | - | constructed primarily for the carriage of goods and                              |
|      | - | one wheel at front, 2 at rear.   |

- LEG2 - over 450 kg *Unladen Mass* and  
- constructed primarily for the carriage of goods and  
- 2 wheels at front, one at rear.

A vehicle constructed for both the carriage of persons and the carriage of goods shall be considered to be primarily for the carriage of goods if the number of seating positions times 68 kg is less than 50 per cent of the difference between the *Gross Vehicle Mass* and the *Unladen Mass*.

These Guidelines are applicable to motor cycle type *trikes* within the LEM1 and LEP1 subcategories. These will generally be a motor cycle derivative, with a fabricated rear frame section and an original motor cycle front frame section, or a vehicle powered by a car engine and transmission and utilising a purpose built frame.

ADRs and AVSRs that are applicable to *trikes* are summarised in Appendix LE1-2 of this document.

If a *trike* exceeds a Gross Vehicle Mass of 1000 kg, it is no longer defined as a motor tricycle, and is therefore not covered by these Guidelines. These vehicles are classified as MA, MC or NA category vehicles, and must comply with ICV requirements applicable to passenger cars.

## 2 TECHNICAL AND SAFETY REQUIREMENTS

*Trikes* covered by these Guidelines fall into the LEM1 and LEP1 categories. The ADR vehicle category listing classifies *LE-type* vehicles as motor tricycles. Consequently, all ADRs and AVSRs applicable to motor cycles are applicable to *trikes*. There are also additional ADRs and AVSRs applicable to *trikes* that are not applicable to motor cycles. Relevant ADRs and AVSRs applicable to *trike* construction are summarised in Appendix LE1-2 of this document.

If a *trike* exceeds a Gross vehicle Mass (GVM) of 1000 kg, it is no longer defined as a *motor tricycle*, and is therefore not covered by these Guidelines. These heavier vehicles are classified as MA, MC or NA ADR category vehicles, and must comply with the ICV requirements for passenger cars.

Where proof of full ADR compliance may not be practical, the vehicle builder will be required to demonstrate compliance with the intent of the ADR. Comparative assessments may be acceptable where components have been sourced from an already certified vehicle.

*Trikes* built to these guidelines qualify under Code LO4 for LEM1 category *trikes* and Code LO5 for LEP1 category *trikes*.

The checklists for LO4 and LO5 are referenced in Appendix LE1-4. The checklists may be copied. In fact it is recommended that the builder use a separate copy of the checklist to ensure no item or requirement is forgotten during the construction phase. In these circumstances the *Signatory* must use a separate and independent checklist.

### 2.1 FRAMES

#### 2.1.1 Signatory Certification

All frames, whether a full purpose built frame, or a frame section attached to a production motor cycle frame, will require certification by a *Signatory*.

The *Signatory* must firstly certify that the design and materials proposed are satisfactory for safe road use, and secondly, that on completion, the vehicle has been constructed in accordance

with the original approval, and to a satisfactory standard of workmanship. The latter will require an inspection of the vehicle at rolling chassis stage, and prior to grinding/smoothing of welds and application of any surface finish. (i.e. paint or powder coat). The *Signatory* may require Non-Destructive Testing, such as radiography, of critical weld areas.

A final *Signatory's* report will be required to certify that the vehicle is sound in its design and construction, has been constructed to a satisfactory standard of workmanship, and compliance with relevant ADRs and AVSRs has been met. A completed checklist must accompany the *Signatory's* report. Please check with your local Registration Authority about the processes involved in retaining reports for audit and/or the need to submit reports to the Authority. While the technical standards are the same across Australia, administrative arrangements may differ.

Note that for LEM1/LEP1 vehicles where the motor cycle frame being used is not the original manufacturer's frame for the motor cycle derivative being used, e.g. a *custom* frame, a *Signatory's* report will be required certifying that the frame being used is satisfactory for the *trike* application.

### 2.1.2 Welding

Frame welding is to be conducted with the frame constrained in a suitable frame jig to ensure alignment is maintained. It is recommended that frame welding be carried out by a certified welder to the *Signatory's* certified weld procedures.

Please refer to Appendix C in Section LZ *Appendices* for further mandatory requirements and information about welding.

### 2.1.3 Frame Vehicle Identification Number (VIN)

Any original manufacturer's ID/Identification Plates and/or frame numbers must not be removed.

A VIN issued by a jurisdiction must be attached to the vehicle in accordance with that jurisdiction's procedures.

## 2.2 FASTENERS

Specified below in Table 1 are the minimum standards acceptable for the choice of nuts and bolts to be used on *trikes*, unless supported by specific engineering design.

**Table 1: Minimum Bolt Sizes.**

Bolt Specifications	Typical Application
Ungraded bolts -	Panel fixing, lightly loaded brackets
SAE Grade 8 or - Metric 10.9 bolts	Brake calipers, master and slave cylinder mounts and all heavily loaded assemblies.

Stainless steel bolts must not be used in high load or stressed situations as they do not possess high tensile strength. It is recommended that these bolts be used in locations where the use of ungraded bolts is permitted.

Refer to Appendix A in Section LZ *Appendices* for further mandatory requirements and information about fasteners.

## 2.3 STABILITY COMPLIANCE TESTING

It must be demonstrated that the *trike* being constructed complies with the requirements of Clause 42.21 of ADR 42/04 *Stability Requirement (LEM, LEP and LEG Vehicles Only)*.

Compliance requires that the height of the centre of mass of the vehicle must not exceed: -

- The horizontal distance from the centre of mass to the nearest roll axis in the case of LEM1 and LEP1 vehicles.

Demonstration of compliance will require a physical stability test to be conducted as detailed in Clause ADR 42.21. The stability test must be conducted or witnessed by the *Signatory*, who is to certify the result, using the proforma provided in Appendix LE1-1. A *calculated* compliance without a physical stability test is not acceptable. The vehicle must be in a fully completed state, with all components, bodywork etc fitted, at the time of stability testing.

Where a *trike* is fitted with car tyres, for the purpose of calculating the distance from the centre of gravity to the roll axis, the track is taken as being from the outer contact edge of the tyre tread of one wheel, to the outer contact edge of the tread of the other tyre. This is considered to be the *effective* track.

The battery may be removed during stability testing to avoid acid spillage.

## 2.4 ENGINES

Where a car engine is being utilized in a LEP category vehicle, the vehicle emissions must comply with the requirements of ADR 37/01. Compliance with the requirements of the IM240 test as detailed in Code LT3 in Section LT *Test Procedures*, will be deemed as sufficient evidence of compliance with the ADR.

Where a car type engine is used, all drive belts and rotating parts must be adequately shielded.

## 2.5 EXHAUST SYSTEMS

Exhaust system noise must not exceed 94db (A) with the vehicle stationary in accordance with the AVSR.

The exhaust system must not have sharp edges or protrusions.

Adequate shielding must be provided to prevent rider/passenger contact with the exhaust system.

## 2.6 BRAKES

Braking systems utilising a combination of hand and foot controls to apply front and rear brakes separately must meet the requirements of the front and rear brake tests of ADR 33. LEP vehicles which utilise a single foot pedal to operate the brakes on all three wheels must comply with ADR 31.

A parking brake is required on all *trikes* in accordance with ADR 33, and must be capable of holding the vehicle stationary, for not less than five minutes, facing in either direction on a gradient of 30%. The application force required must not exceed 405N if foot operated or 245N if hand operated.

Master cylinders must have a displacement volume of at least 1.5 times the combined new to worn displacement of all wheel cylinders/calipers that it activates.

The brake pedal must not contact any part of the vehicle before the master cylinder piston has reached the end of the piston travel.

Pushrods between the master cylinder and the pedal arm must be straight and must act through the centreline of the master cylinder bore. In circumstances where a straight pushrod cannot be used alone, additional leverage systems such as a *bell crank* may be used provided that the system is assessed and certified by a *Signatory*.

Manufactured pushrods used in braking systems must have a diameter not less than that specified in Table 2 below.

**Table 2: Minimum Pushrod Diameters According to Length**

Pushrod Length	Pushrod Diameter (minimum)
Up to 250mm	10mm
250 to 400mm	12mm
400 to 600mm	14mm

Rigid brake pipes must be made from tubing designed for use with automotive braking systems. Connections must be flared in a manner suitable for the chosen fittings, and the tubing must be supported with a rigid mount at intervals of no more than 300mm. Brake pipes must not be joined by welding or brazing.

Only flexible brake lines and hoses marked as complying with ADR 7/00 or the applicable SAA, SAE, BS, JIS, DIN, ISO or ECE Standard are acceptable. Flexible braided hoses must not be forced into a radius tighter than the manufacturer's specified minimum radius for each hose diameter.

Brake lines that pass under the frame must be protected. Brake lines must be installed without sharp bends. Radius of bends must not be tighter than the manufacturer's specified minimum radius for each tube diameter.

## 2.7 FRONT SUSPENSION

When designing a *trike*, there are a number of types of front suspension that may be considered. Each has particular advantages and disadvantages and all are acceptable provided that it is possible to show that the arrangement used is adequate for the task. Fork type front suspensions will be dealt with here. The design of *hub-centre* and car type front suspension systems is beyond the scope of this document.

In all cases, this is a critical safety component and great care must be taken in design and manufacture. Professional advice should be sought.

### 2.7.1 Telescopic Forks

The simplest option is the fitment of telescopic forks from a motor cycle. These are widely available and can be relatively inexpensive. They are designed to withstand loads applied principally in line with the fork legs, as occurs with a motor cycle that leans in corners. When fitted to a three-wheeled vehicle such as a *trike* or a sidecar combination, the forks are subjected to lateral (sideways) forces when cornering. They may also be subjected to increased bending loads under braking due to the greater mass of the vehicle. This can lead to

the suspension action being impaired, bushes and seals failing prematurely or, in extreme cases, failure of the fork legs.

It is therefore very important to ensure that the forks used are sufficiently stiff in bending to resist the expected cornering and braking loads. It is also recommended that the fork assembly is reinforced by connecting the sliding elements of the fork legs with a suitable brace. A larger diameter front axle may also be used to enhance rigidity.

The steering geometry of the donor bike (the rake and trail dimensions) are unlikely to be appropriate for a *trike*. New fork yokes (triple clamps) may be required to adjust this.

Telescopic forks tend to compress excessively (dive) under braking. This should be taken into account when selecting spring rates.

### 2.7.2 Leading Links

Leading link forks are suited to applications where lateral loadings occur. For this reason they are popular on both *trikes* and sidecar combinations. There are 3 main types.

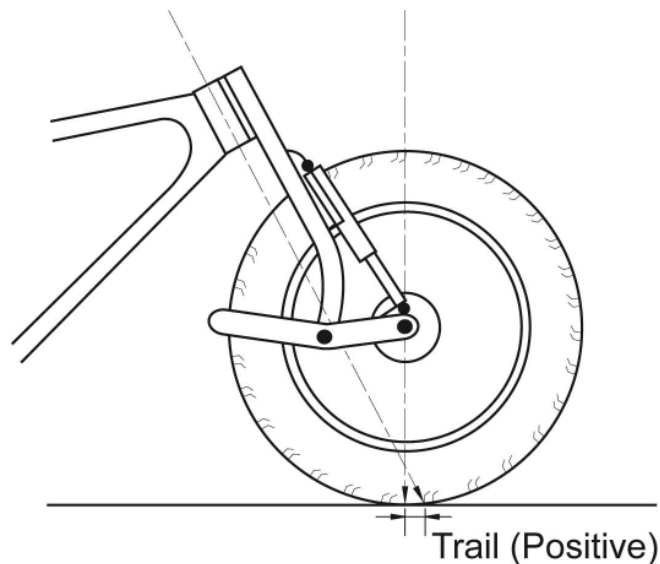
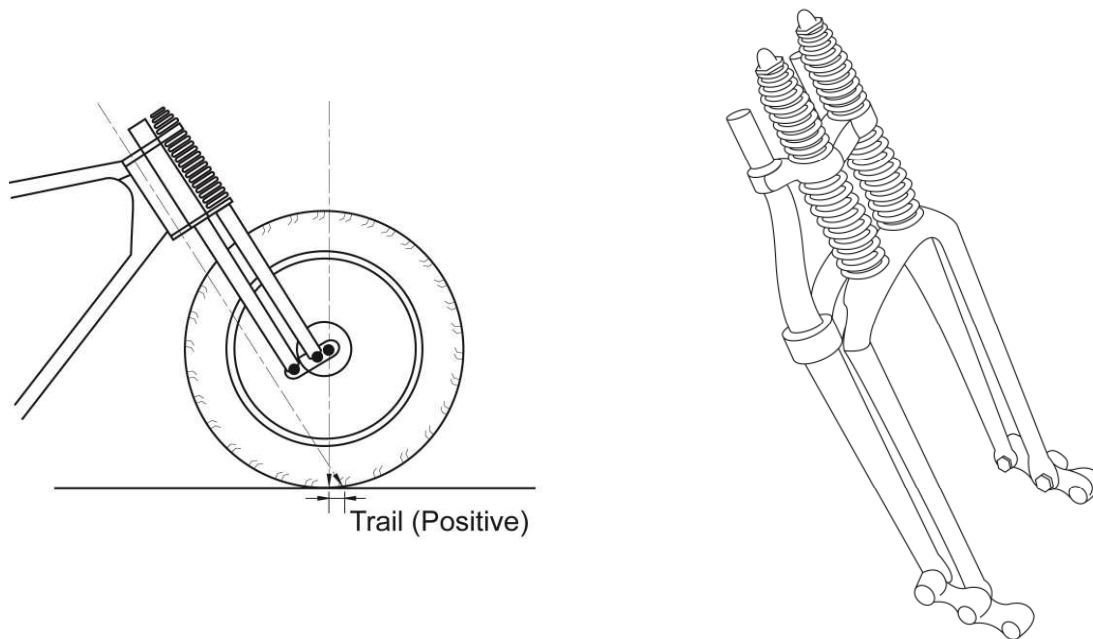

Figure 1: Typical Example of an *Earles Fork*

**Type 1: *Earles* type leading link fork:** An *Earles* type leading link fork consists of a swinging arm similar to that used for motor cycle rear suspensions which is supported by rigid legs extending from the steering head. Suspension is provided by separate coil spring/shock absorber units.

A designed leading link arrangement can incorporate adjustment for trail and spring and damping rates to allow the front suspension and steering to be *tuned* for optimum results.

Fork dive under braking can be eliminated by careful design of the braking system.



**Figure 2: Typical Example of Springers**

**Type 2: Springers.** These differ from the *Earles* type leading link fork in that a short rocking lever on each leg replaces the swinging arm. They are based upon a design used for many years by certain motor cycle manufacturers. They can be better than telescopic forks at resisting lateral and braking loads and can be designed with *anti-dive* characteristics. However, *springers* generally lack the adjustability and rigidity of the *Earles* type leading link and it may be found that the vertical travel is too limited to offer a comfortable ride.

Fabricated suspension systems, either front or rear, will require *Signatory* certification with respect to welding and metallurgical soundness (refer to Appendix C in Section LZ *Appendices*).

Where a suspension system, in particular a front fork assembly, is sourced from a production vehicle and is unmodified, it must be from a vehicle of similar front axle loading.

Where a *trike* utilises a production motor cycle frame assembly, the front forks supplied by the motor cycle manufacturer for the particular motor cycle being used are considered adequate.

Where forks designed for use on a production vehicle are used and these are subject to either increased loading, a more severe rake angle or where they are extended, the assembly will require *Signatory* certification.

Due to the increased lateral loading applied to the forks of a *trike* over those of a motor cycle, leading link type forks will generally give superior performance to telescopic designs and should be considered for use where practicable.

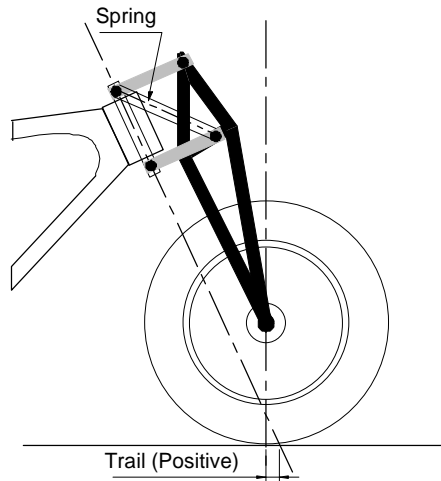

**Figure 3: Example of Trapezoidal or Girder Forks**

### **Type 3: Girder Forks.**

*Girder forks* are fitted to many *trikes*. These consist of a girder type assembly (hence the name) connected to the steering stem via a parallelogram arrangement of links to allow suspension movement. Girders can be made extremely stiff to deal with the additional loadings to which *trike* forks are subjected. However, the unsprung weight of girder forks is high, reducing ride quality, and the wheelbase of the vehicle will shorten as the suspension compresses under load.

When fitting girders it is important to ensure that the forks chosen are sufficiently stiff in bending to resist the expected cornering and braking loads. It should not be assumed that a girder fork assembly designed for use on a motor cycle will be of adequate strength and rigidity for a *trike*.

The steering geometry (the rake and trail dimensions) of girder forks is critically dependent on the lengths and pivot point positions of the links connecting the girder to the steering head. It is particularly important to ensure that the trail dimension does not approach zero or become negative at any point in the suspension's travel (refer to Figure 3).

## **2.8 REAR SUSPENSION**

When designing a *trike*, there are a number of types of rear suspension which may be considered. Each has particular advantages and disadvantages and all are acceptable provided that it is possible to show that the arrangement used is adequate for the task.

In many cases, the type of rear suspension employed will be influenced by the source of the other mechanical components of a particular *trike*.

In all cases, this is a critical safety component and great care must be taken in design and manufacture. Professional advice should be sought.

### **2.8.1 Rigid Rear Ends (Hardtail)**

The simplest option for light *trikes* is to bolt a car type rear axle directly to the rear end of the frame.

Such an arrangement has no moving components to wear and there is no need to select appropriate spring and damping rates. It is also much easier to arrange a reliable drive-line as the distance from the differential to the rear of the gearbox is fixed, eliminating the problems of tensioning a chain drive or incorporating sufficient length variation in a shaft drive.

However, the ride quality will be poor, necessitating the use of at least a sprung saddle for rider comfort. Handling, on bumpy surfaces, is unlikely to be as good as if suspension were provided. The fixed rear axle will also be subject to large shock loadings, some of which will be transmitted into the frame. It is important to ensure that all components and fabrication techniques used are capable of withstanding such loads.

### 2.8.2 Live Axle Rear Ends

Falling between the rigid arrangement and the various types of independent suspension in complexity is the live axle.

In this case, a car type solid axle is again used. The suspension action is usually provided by coil spring/damper units and the axle is located longitudinally by pivoted radius arms and laterally by either a Panhard rod or a radius arm arrangement. The so called *four bar* rear suspension shown in Figure 4 below is a typical form of this type of suspension.

The ride and handling will generally be better than for the rigid arrangement but careful attention must be paid to spring and damper rates.

It is also important to ensure that the geometry of the radius arms and Panhard rod does not cause excessive bump steer. The suspension should be arranged so that any longitudinal movement of the axle as the suspension compresses is towards the front of the vehicle.

Suggested limits for fabricated mild steel *four bars* are shown in Table 3.

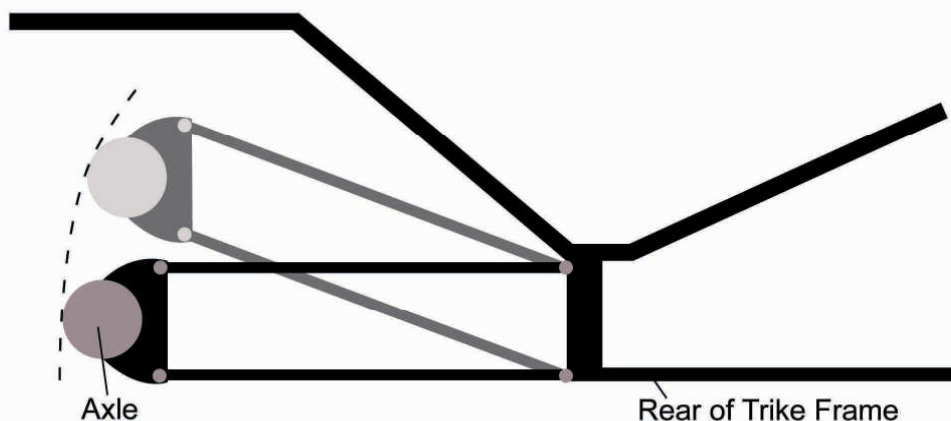

Figure 4: Typical Example of *Four-bar* suspension locaters

Table 3: Suggested Limits for Fabricated Mild Steel *Four-Bars*

Maximum Length –	900mm
Minimum Outside diameter of Tube –	22mm
Minimum Wall Thickness –	3mm

**Note:** If threaded ends are used with 3mm wall thickness tubing, a bush must be welded into the end of the tube to accommodate the thread.

Heim joints must not be used as a suspension or steering component without *Signatory* certification.

### 2.8.3 Independent Rear Suspensions

There are a large number of designs of independent rear suspension (IRS) which may be used and a description of every type is beyond the scope of this document. However, IRS may be divided into two main categories.

#### 2.8.4 Type 1 IRS - Swing Axles

In a swing axle suspension, the differential is rigidly mounted in the centre of the frame and a separate axle shaft each side is pivoted outboard of the differential as illustrated in Figure 5 below.

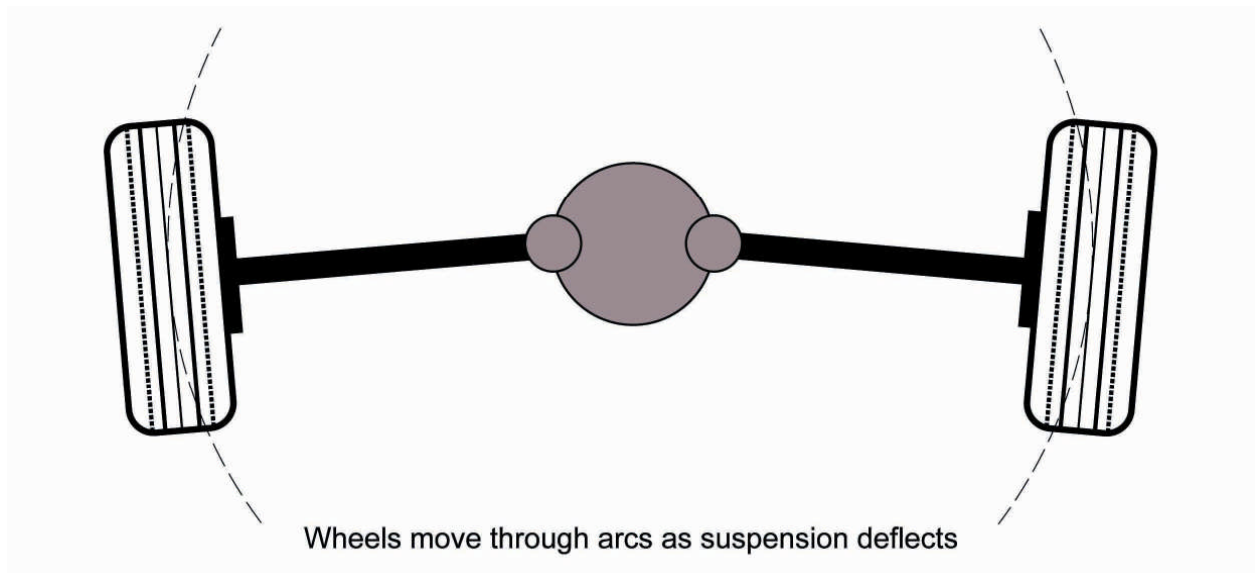

**Figure 5: Simple Swing Axle Configuration**

The outer end of each axle shaft is usually located longitudinally by a trailing arm. This arrangement was used by Volkswagen (VW) and is, therefore, common on *trikes* using VW transaxles. Springing may be provided by a coil spring/damper unit at each side or, in the case of VW based vehicles, by the original torsion bar springs mounted ahead of the axle.

This is the simplest form of IRS and its use may be dictated by the use of an older VW transaxle. With careful selection of spring and damper rates and attention given to trailing arm length and ride height, a comfortable ride and good handling may be obtained.

As the suspension rises and falls, the wheels cannot remain vertical (their camber angle will change), nor can they rise and fall in a straight line. The action of a trailing arm will also cause the ends of the axle shafts to move back and forth longitudinally.

Due to the camber changes inherent in this type of suspension, care must be taken in selecting appropriate wheel rim and tyre widths. It may be found that a wide tyre will contact the road only at one edge, reducing the available grip and resulting in uneven wear.

For optimum handling, it is recommended that the ride height be set so that the axle shafts are horizontal when the vehicle is normally operated, so that they will tend to slope up towards the wheels as the load increases or the suspension compresses over bumps.

When designing the radius arms, it is important to consider that a longer arm will allow less longitudinal displacement of the wheel for a given suspension movement. This will assist in minimising bump-steer and roll-steer effects.

### 2.8.5 Type 2 IRS – Multiple Link Systems

More sophisticated IRS arrangements attempt to eliminate the disadvantages of swing axles at the expense of greater complexity. There are many different designs that use a variety of means to control wheel movement. Most operate on the basic principle illustrated in the *Double Wishbone* example shown in Figure 6 below.

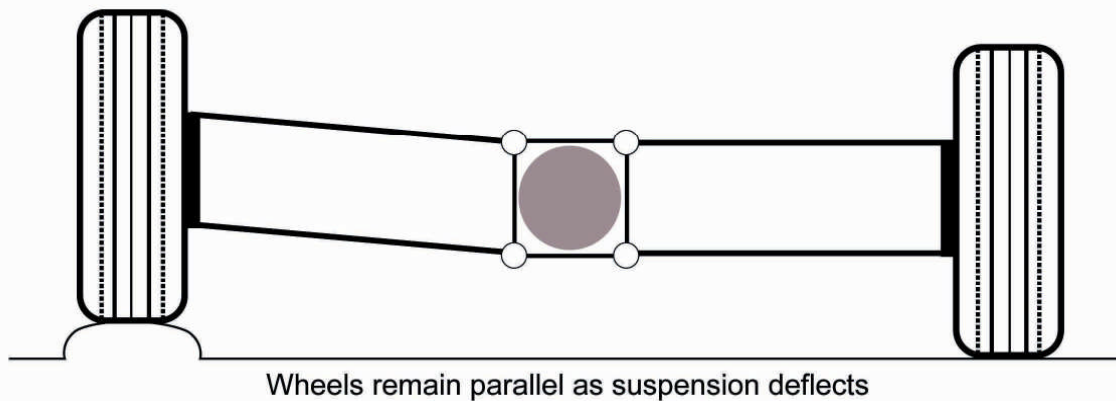

**Figure 6: Example of a *Double Wishbone* Rear Suspension**

All these systems are designed to minimise the change in wheel camber during suspension movement. Most employ coil spring/damper units for suspension and trailing arms for longitudinal wheel location.

Ride quality and handling is generally very good, although the design of the system itself, together with its attachments, may be more complicated than other designs.

The use of an existing suspension system complete with a mounting sub-frame (e.g. Jaguar) can simplify the design process and subsequent installation.

As is the case with other systems, attention must be paid to spring and damping rates and to the elimination, as far as practicable, of bump-steer and roll-steer.

## 2.9 GROUND CLEARANCE

Ground clearance must be at least 100mm and in the event of a tyre failure, no part of the vehicle other than the wheel rim must be able to come in contact with the road surface.

### 2.10 RIMS AND TYRES

If passenger car tyres are fitted, they must comply with ADR 23/01. The speed and load capacity, placarding and tyre/rim combination must be suitable for the *trike* and must comply with ADR 24/02 or Clause 25 of ADR 42/04.

Maximum rear rim width for LEM1/LEP1 vehicles is recommended to be 200mm (8").

Tyres must be fitted to rims in accordance with the Australian Tyre and Rim Association Manual.

Double sided safety rims must be fitted.

Each wheel rim must not have more than one weld around its circumference.

Slotted stud type multi-fit rims must not be used.

Where a passenger car tyre is fitted to the front wheel of LEM1/LEP1 vehicles, the front and rear tyres must all be of the same carcass construction, i.e. all radial, or all belted bias.

A tyre placard must be attached to the vehicle clearly showing the rim and tyre sizes, and tyre inflation pressures applicable to that vehicle.

## 2.11 MAXIMUM WIDTH

The maximum overall width of a *trike* must not exceed 1850mm.

## 2.12 FUEL SYSTEM

Fabricated fuel tanks must be soundly constructed from appropriate materials.

The fuel tank must be compatible with the selected engine with regard to breathing, fuel return and connection to the evaporative emission control system.

Fuel lines must be secured at intervals of no more than 300mm, and must not pass under frame rails unprotected.

Refer to Section LM *Fuel Systems* for more information about fuel systems, fuel lines and fuel tanks, particularly if a motor car engine is used.

## 2.13 SEATING AND SEATBELTS

Seats must be securely fitted. Hinged or removable seats must not release under extreme deceleration.

Passenger seating positions, other than a pillion passenger seat directly behind the rider, require lap seatbelts to be fitted.

All seatbelts used must be new and marked as complying with the appropriate Australian Standard.

Seatbelt anchorage points must be installed in accordance with the general strength and location requirements of ADR 5/00 (refer to Appendix LE1-3).

Seatbelts must be connected to the seatbelt anchorage with bolts designed for seatbelt use. A locking device or a nyloc nut must retain each seatbelt mounting bolt that attaches to a non-captive nut.

## 2.14 HANDLEBARS

While there are no specific provisions for *trike* handlebars, it is recommended that they comply with the requirements for motor cycle handlebars in accordance with Rule 55 of the AVSR. The following measurements need to be taken with the handlebars in a stationary and straight ahead position.

- 1) The handlebars must extend at least 250mm, but not over 450mm, on each side of the centre line of the vehicle;
- 2) In taking a measurement for (1), mirrors and lights mounted on the handlebars can be disregarded;

- 3) The lowest part of the handgrip on the handlebars must not be higher than 380mm above the attachment point of the handlebars to the vehicle; and
- 4) Handgrips on the handlebars must be fitted symmetrically.

Handlebars must be constructed in a manner and of material conforming to accepted practice for motor cycles. Conventional tubular handlebars would generally be expected to be constructed from steel tubing of between 22mm and 25mm outside diameter and of minimum 1.6mm wall thickness.

## 2.15 MUDGUARDS

*Trikes* must have mudguards that comply with the requirements of ADR 42/04 fitted to all wheels.

## 2.16 DRIVE SHAFTS, CHAINS AND BELTS

Drive shafts, chains and belts must be adequately protected such that rider/passenger contact with moving or rotating parts is prevented. Note that more extensive guarding may be required than is necessary for a solo motor cycle.

## 2.17 ELECTRICAL

### 2.17.1 LIGHTING

Lighting equipment must be in accordance with ADR 67/00.

### 2.17.2 Headlights

The minimum requirement for both LEM1 and LEP1 vehicles is for a centrally mounted, single headlamp – a centrally mounted, dual headlamp assembly is also acceptable for both vehicle categories.

Maximum headlight height is 1400mm and the minimum 500mm to the centre of the light.

### 2.17.3 Brake Lights

Two brake lights must be fitted to LEM1/LEP1 vehicles, one on either side, with an additional high mounted third brake light.

Brake lights must be red in colour.

Brake lights must be at least 350mm but less than 1500mm from the ground to the light centre.

### 2.17.4 Parking/Tail Lights

Two park/tail lights must be fitted to the rear of LEM1/LEP1 vehicles, one on either side, and one park light to the front. The rear lights must be positioned with centres no more than 510mm inboard from the vehicle extremity on either side, and at least 600mm apart, equidistant from the centre line of the vehicle.

Lights must be red to the rear, white to the front. Power must not exceed 7 watts and they must be visible at 200m.

Front parking lights may be positioned in the headlight assembly and rear parking lights may be incorporated with the brake lights in the rear light assemblies.

Rear park/tail lights must be at least 350mm but less than 1500mm from the ground to the light centre. Front park lights must be at least 500mm but less than 1400mm from the ground to the light centre.

#### 2.17.5 Direction Indicator Lights

Flashing indicator lights must be amber in colour. They must be located so that other road users will have an indication of the directional change intended.

The centres of rear lights on LEM1/LEP1 vehicles must be no less than 600mm apart and equidistant from the centre line of the vehicle in accordance with Rule 103(1)(b) of the AVSR.

The centres of front lights on LEM1/LEP1 vehicles must be no less than 300mm apart and equidistant from the centre line of the vehicle in accordance with Rule 103(1) (a) of the AVSR.

Lamp centre height must be between 350mm and 1500mm above ground level.

#### 2.17.6 Number Plate Light

A white light of 7 watts or less must be fitted to the rear to illuminate the rear number plate when the parking lights or headlights are switched on. All letters and numbers on the number plate must be clearly visible when viewed 20m from the rear of the vehicle. Performance must be in accordance with Rule 90 of the AVSR.

#### 2.17.7 Hazard Lights

Hazard lights that comply with ADR 67/... must be fitted to all categories of *trikes*.

The *Vehicle Hazard Warning Signal* must remain capable of being actuated even when the device which controls the starting and stopping of the engine is in such a position that operation of the engine is impossible.

#### 2.17.8 Automatic Transmission Safety Switch

All *trikes* fitted with automatic transmissions (manual valve bodies included) must be fitted with a neutral/park safety switch. The switch must prevent operation of the starter motor when a forward or reverse gear has been selected. Transmission selectors must be designed so that there can be no accidental engagement of reverse gear.

#### 2.17.9 Wiring

Wiring must comply with Clause 9 of ADR 42/04.

All sections of the wiring loom must be insulated and secured at intervals of not more than 600mm. Wiring is not to be secured to either brake or fuel lines without approved automotive insulating clips attached. It is preferred that wiring is kept away from fuel lines.

Wiring must be adequately secured and protected from damage and be clear of exhaust and moving parts.

All wiring must be neat and tidy, and any wiring passing through metal sections must be adequately protected from chafing, e.g. by the use of rubber grommets.

#### 2.17.10 Batteries

Batteries must be secured and placed in a container suitable for the purpose of holding a battery.

Battery terminals and wiring must be positioned so that there can be no accidental shorting to ground of the live terminal. The battery leads must be secure and kept away from rotating components, fuel system components, and exhaust systems.

Fusible links between the battery and powered components are highly recommended.

## 2.18 INSTRUMENTATION

Instrumentation and warning lamps must be fitted in accordance with ADR 18/02. Odometers reading to a maximum of 99,999 km will be accepted on LEP category *trikes* where the speedometer and speedometer drive mechanism are driven from the front wheel and are taken from the same donor motor cycle as the front wheel and forks.

Speedometer and odometer accuracy must be as specified in Clause 18.5 of ADR 18/02.

## 2.19 REVERSE GEAR

All LEP category Motor Tricycles must be able to be driven both forwards and backwards in accordance with ADR 42/04.

## 2.20 CERTIFIED VEHICLE MASS

As the mass of the finished, unladen *trike* is required to determine its category, it is recommended that the *Signatory* certifying the stability test includes the unladen mass in the vehicle report, since the vehicle must be weighed during the stability test process.

**Note** Not all certified public weighbridges are able to accurately measure weights under one tonne. In these cases alternative weighing devices must be used to provide the accurate mass of the vehicle.

## 2.21 IMMOBILISERS

LEP *trikes* must be fitted with an anti-theft lock as per ADR 25/02. This generally means a steering lock or a gear lock must be fitted.

Alternatively, a self-arming immobilising device that complies with the standards listed below may be fitted to LEP *trikes* where it is not practical to install a steering locking device complying with the ADR.

- an immobiliser fitted to a vehicle as an integral part of an alarm system complying with AS/NZS 3749.1:1997 *Intruder alarm systems — Road vehicles*, jointly published by Standards Australia and Standards New Zealand; or
- an immobiliser that complies with AS/NZS 4601:1999 *Vehicle Immobilizers*, jointly published by Standards Australia and Standards New Zealand.

## 2.22 VEHICLE CONDITION

When presented for registration a *trike* should be in *as new* condition. All components used must be in a sound, serviceable condition, and should be either new or refurbished to a high standard.

### 3 COMPLIANCE WITH REDUNDANT AUSTRALIAN DESIGN RULES

In the review of the ADRs a number of ADRs, or clauses within ADRs have been made redundant. A number of these ADRs are also applicable to *trikes* and will soon have no effect. Many of these requirements have been superseded by clauses contained in ADR 42/04.

To assist *trike* builders in identifying these ADRs, reference has been specifically made in the description of these ADRs in Appendix LE1-2 - *Summary of Applicable Australian Design Rules*.

Compliance with an ADR that has subsequently been superseded by ADR 42/04 will be deemed to constitute compliance with ADR 42/04. For example, if a braking system is used from an existing production motor cycle with hoses that comply with ADR 7, these hoses will be deemed to comply with the relevant clause in ADR 42/04.

## 4 APPENDICES

### APPENDIX LE1-1

#### ADR 42/04 Stability Test Report and Explanatory Diagrams

##### GENERAL DETAILS:

Owner/Builder:

---

Frame Number:

---

Configuration Category (LEM/LEP1)

---

Engine Number:

---

Wheelbase (W): mm

---

Track (t) (*actual or effective*) mm

---

Rolling Radius (r): mm

---

Reference Angle ( $\theta$ ): degrees

---

Number of Seating Positions:

---

##### AXLE LOADS:

##### LEM/LEP1 category:

Front Axle Load (F): kg

---

Rear Axle Load (Left): kg

---

Rear Axle Load (Right): kg

---

Total Rear Axle Load (R): kg

---

Certified Tare Mass: (**F + R - test masses = tare**): kg

---

Continued Overleaf

**CENTRE OF MASS:**

Longitudinal Location:

$L = WR/(F + R) =$  mm

Height Location:

$h = r + (W - L)/\tan\theta =$  mm

Horizontal Location:

$d = L \sin[\arctan(t/2W)]$  (LEM1/LEP1 vehicles) = mm

**CONCLUSION:**

The vehicle as tested complies with the requirements of Section 42.21 of ADR 42.04

Yes:

No:

Test conducted by:

Signatory's Signature:

Date:

Address

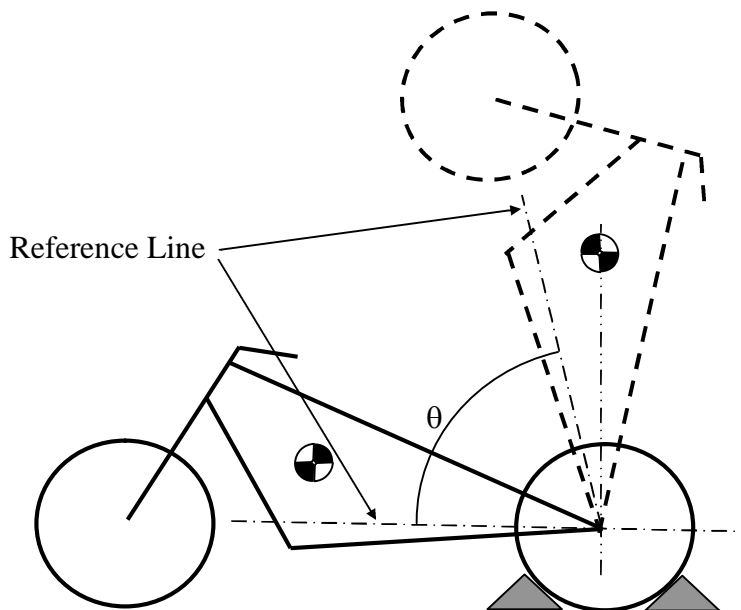
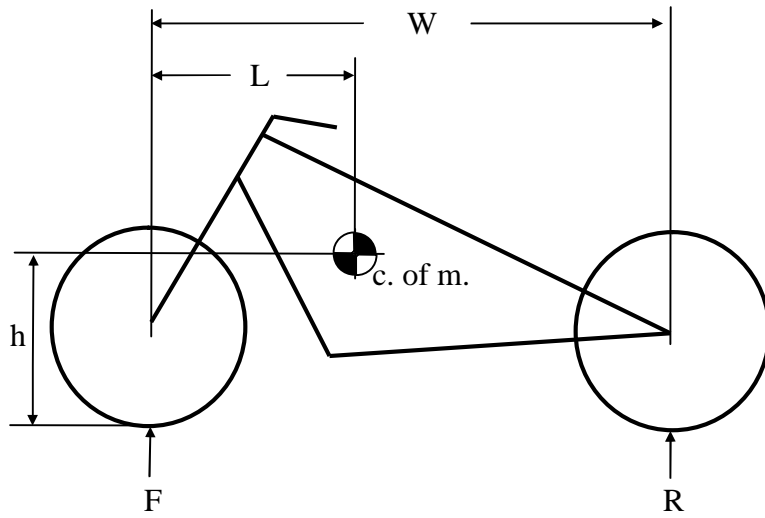

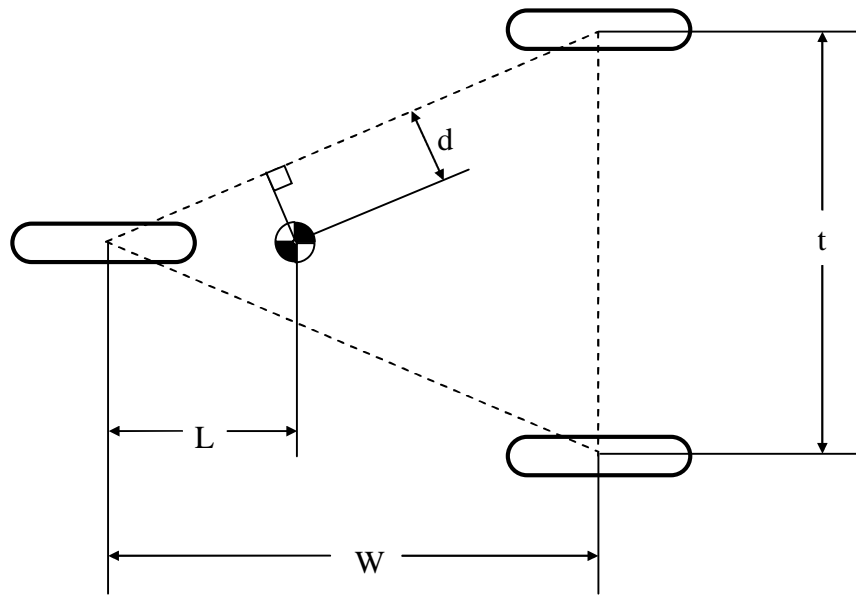

## APPENDIX LE1-2

### Summary of Applicable Australian Design Rules

Following is a summary of ADRs and a summary of the AVSR that are applicable to motor cycle type *trikes*. Note that not all of the ADRs mentioned in the summary will be applicable to all vehicles. Advice from a *Signatory* may be required to confirm which ADRs and AVSR will be applicable to the LEM or LEP vehicle under consideration.

#### AUSTRALIAN DESIGN RULES SUMMARY

##### ADR 1 REVERSING LAMPS

Lamps that are switched on automatically whenever reverse gear is selected and the ignition is *on* to signal the driver's intention to reverse and to aid the driver in reversing manoeuvres at night. These lamps must only operate when the vehicle is in reverse gear and must be amber or white.

##### ADR 2 SIDE DOOR LATCHES AND HINGES

Side door latch and striker assemblies and hinges that are able to resist accidental opening through crash impact or distortion. When locked by controls inside the vehicle, outside door handles must be inoperative. When locked, regardless of operation of other child-proof locking systems, if fitted, the rear doors must not open by movement of the inner door handle. There must also be a fully latched and a secondary latched position.

##### ADR 3 SEATS AND SEAT ANCHORAGES

Requirements for seats and seat attachment assemblies and installation to reduce failure in crashes. Hinged or folding seats must be self-locking with the lock release within reach of the seat occupant or any other person seated immediately behind the seat. ADR 3A specifies additional requirements for seats intended to be fitted with child restraints.

##### ADR 4 SEATBELTS

Requirements for seatbelts for all adult seating positions to restrain vehicle occupants under impact conditions. Specifies the type of belt, material properties and buckle design features. Compliance with Australian Standards is necessary but not sufficient proof of compliance with this Design Rule.

##### ADR 5 ANCHORAGES FOR SEATBELTS

Requirements for seatbelt anchorage points to ensure that seatbelt assemblies are securely fixed to the vehicle structure in specified areas and provide a safe and comfortable restraint system.

##### ADR 6 DIRECTION INDICATORS

Specifies flashing amber lamps at front and rear with specified levels of brightness and fields of view and readily distinguishable to warn other road users of the driver's intention to turn to the right or left.

##### \*ADR 7 HYDRAULIC BRAKE HOSES

Repealed – This standard ceased to have effect for new vehicles as from 9 December 2003, the requirements have been incorporated in ADR 42/04.

Specifies minimum standards of performance and durability for flexible hoses and end fittings in hydraulic brake systems to reduce risk of failure. Hose assemblies marked SAE J 1401 are acceptable.

#### **ADR 8 SAFETY GLAZING MATERIAL**

Requires glass in motor vehicle windscreens, windows and interior partitions to be of an automotive safety type such as toughened or laminated (and be so marked). Windscreens must be clear glass and transmit at least 75% of visible light in the primary vision area. Tinted bands are permissible outside this area.

#### **\* ADR 9 STANDARD CONTROLS FOR AUTOMATIC TRANSMISSION**

**Repealed.** However, the requirements for automatic transmission controls are now in ADR 42/..., which includes the requirement that the engine of a vehicle fitted with an automatic transmission must not be capable of being started in any forward or reverse gear.

#### **ADR 10 STEERING COLUMN**

Requires that steering wheel and column assemblies must collapse under specified forces to reduce injuries to drivers on impact and limits the horizontal intrusion of the steering column into the cabin.

#### **ADR 11 INTERNAL SUN VISORS**

If fitted, sun visors must be suitably padded and without dangerous projections or noticeable internal frames in order to reduce head injury on impact with the visor or panel work or windscreen glass behind it.

#### **\* ADR 12 GLARE REDUCTION IN FIELD OF VIEW**

**Repealed.** This standard ceased to have effect for new vehicles as from 9 December 2003.

Requires a low reflective finish on windscreen wiper arms and blades, interior windscreen mouldings, horn rings and steering wheel components. Interior rear vision frames and mountings, steering column mounted control lever and gear selection quadrants to minimise glare from these features in the driver's field of view.

#### **ADR 14 REAR VISION MIRRORS**

Defines requirements for the type, location, field of view, reflecting capabilities and mounting details of rear vision mirrors.

#### **\*ADR 15 DEMISTING OF WINDSCREENS**

**Repealed** – This standard ceased to have effect for new vehicles as from 9 December 2003. Similar provisions are now contained in ADR 42/04.

Specifies requirements for demisting equipment to maintain the driver's forward vision clear of mist.

#### **\*ADR 16 WINDSCREEN WIPERS AND WASHERS**

**Repealed** – This standard ceased to have effect for new vehicles as from 9 December 2003. Similar provisions are now contained in ADR 42/04.

Wipers to have two operating speeds and be capable of wiping defined areas of the windscreen, with washers able to supply sufficient fluid to the wipers over ten wiping cycles.

## ADR 18 INSTRUMENTATION

Defines positions of certain important instruments and warning lamps and requirements for their illumination at variable brightness levels.

## ADR 19 INSTALLATION OF LIGHTING AND LIGHT-SIGNALLING DEVICES ON L GROUP VEHICLES

Ensures that the installation of lighting and light-signalling devices on motor cycles and mopeds is such that the effective operation of these devices is not impaired.

## \*ADR 20 SAFETY RIMS

**Repealed.** This standard ceased to have effect for new vehicles as from 9 December 2003.

Specifies that wheel rims on passenger cars will retain a deflated tyre in the event of sudden loss of pressure as in a blow-out.

## ADR 21 INSTRUMENT PANEL

Provides for instrument panels to be suitably padded and free of any sharp projections and edges to reduce head injury on impact.

## ADR 22 HEAD RESTRAINTS

Specifies devices built onto the top of each outer front seating position to reduce *whiplash* type injuries in rear end collisions. When seated, the top of the head restraint must be at about eye level. A clip-on type is unacceptable.

## ADR 23 PASSENGER CAR TYRES

Specifies standards of strength, construction and performance and requires this information to be indicated on labels on the side walls of tyres manufactured for passenger cars and their derivatives.

## \*ADR 24 TYRE AND RIM SELECTION

**Repealed** – This standard ceased to have effect for new vehicles as from 9 December 2003. Similar provisions are now contained in ADR 42/04.

Requires vehicles to be fitted with tyres and wheel rims suitable for the vehicle's speed, mass and usage. Also requires vehicles to have a placard showing the range of tyres and wheels, together with inflation pressures, which the vehicle manufacturer has certified as being suitable.

## ADR 25 ANTI-THEFT LOCK

When the ignition is locked and the key is removed, it must be impossible either to steer the vehicle or alternatively, to engage a forward gear or to release a brake without removing or destroying the lock mechanism. Also minimises the chances of a key fitting more than one lock to less than 1 in 2,000.

## \*ADR 28 EXTERNAL NOISE OF MOTOR VEHICLE

**Repealed;** This standard ceased to have effect for new vehicles as from 1 October 2006. This standard has been superseded by ADR 83/ for new vehicles as from 1 October 2006.

Specifies maximum levels of external noise that motor vehicles other than motor cycles may emit.

## ADR 29 SIDE DOOR STRENGTH

Specifies strength and stiffness requirements for side doors as protection in case of side impact. Generally requires the fitment of a reinforcing beam in the door.

### **\*ADR 31 HYDRAULIC BRAKING SYSTEMS FOR PASSENGER CARS**

**ADR 31/00 has been Repealed:** This standard ceased to have effect for new vehicles as from 29 September 2006.

ADR 31/01 and ADR 31/02 apply only to ADR category LEP vehicles fitted with a single foot pedal controlling front and rear service brakes. Other LEP vehicles must comply with ADR 33/...

Requires split hydraulic braking systems and brake failure warning devices, and specifies stopping performance of passenger cars to ensure safe braking under normal and emergency conditions.

### **ADR 33 BRAKING SYSTEMS FOR MOTOR CYCLES AND MOPEDS**

Specifies independent or split service brakes to ensure safe braking under normal and emergency conditions. Must also provide a visual indication of the brake pad or shoe wear.

### **ADR 34 CHILD RESTRAINT ANCHORAGES AND CHILD RESTRAINT ANCHOR FITTINGS**

Specifies requirements for anchorage points behind each rear seating position of passenger cars to facilitate the satisfactory installation of child restraint systems.

### **\*ADR 37 VEHICLE EMISSION CONTROL FOR LIGHT VEHICLES**

**Repealed;** Superseded by ADR 79 for new vehicles as from 1 October 2006.

Limits fuel evaporation and exhaust emissions from motor vehicles in order to reduce air pollution, and requires operation on unleaded petrol.

### **\*ADR 39 EXTERNAL NOISE FOR MOTOR CYCLES**

**Repealed;** This standard has been superseded by ADR 83/ for new vehicles as from 1 October 2006.

Specifies maximum levels of external noise that motor cycles and mopeds may emit.

### **ADR 40 NOT YET ALLOCATED**

### **\*ADR 41 MANDATORY OPERATION ON UNLEADED PETROL**

**Repealed.** This standard ceased to have effect for new vehicles as from 13 February 2001.

Requires vehicles to be manufactured to operate on *Unleaded Petrol* and have certain associated features such as labels and a small filler tube neck to prevent misfuelling.

### **ADR 42 GENERAL SAFETY REQUIREMENTS.**

Specifies a wide variety of general design and construction requirements to ensure safe operation of the vehicle, e.g. mudguards. Windows, bonnet latches, engine and transmission controls, etc.

### **ADR 43 VEHICLE CONFIGURATION AND DIMENSIONS.**

Specifies a wide variety of requirements for vehicle configurations, dimensions, marking, number plate mountings, label holders, etc..

### **ADR 44 SPECIFIC PURPOSE VEHICLE REQUIREMENTS**

Defines special requirements for the construction of vehicles designed for a specific purpose, e.g. taxis, tow trucks, road trains etc. Requirements include some for the mechanical coupling of vehicles. The requirements of ADR 44/... are related to specific requirements of the particular vehicle. A *specific purpose vehicle* can belong to one or more of the vehicle categories.

## **ADR 45 LIGHTING AND LIGHT-SIGNALING DEVICES NOT COVERED BY ECE REGULATIONS**

Specifies the photometric requirements for lighting and light signalling devices to ensure adequate illumination for the driver of the vehicle and signal to other road users the position, orientation, intention and movement of the vehicle without producing undue glare. Includes requirements for rear marker plates, cabin lamps etc..

## **ADR 46 HEADLAMPS**

Specifies the photometric requirements for headlamps to provide adequate illumination for the driver of vehicles other than motor cycles without producing undue glare for other road users. Specifies the maximum and minimum wattage and light output and distribution.

## **ADR 47 RETROREFLECTORS**

Specifies the dimensional, photometric and stability requirements for reflex reflectors to ensure that they effectively warn of the presence of the vehicle and continue to do so in normal use.

## **ADR 48 DEVICES FOR ILLUMINATION OF REAR REGISTRATION PLATES**

Specifies the photometric requirements for rear registration plate illuminating devices for vehicles other than motor cycles, to ensure that the rear registration plate is adequately illuminated.

## **ADR 49 FRONT AND REAR POSITION (SIDE) LAMPS, STOP LAMPS AND END-OUTLINE MARKER LAMPS.**

Specifies the photometric requirements for vehicle light-signaling devices to signal to other road users the position, orientation and movement of the vehicle without producing undue glare for other road users.

## **ADR 50 FRONT FOG LAMPS**

Specifies the photometric requirements for front fog lamps to provide adequate illumination for the driver of the vehicle without producing undue glare for other road users.

## **ADR 51 FILAMENT LAMPS**

Specifies the dimensional and photometric requirements for filament globes to ensure interchange ability and correct functioning when installed in a lamp.

## **ADR 52 REAR FOG LAMPS**

Specifies the photometric requirements for rear fog lamps that signal to other road users the position, orientation and movement of the vehicle without producing undue glare for other road users.

## **ADR 53 FRONT AND REAR POSITION LAMPS, STOP LAMPS, DIRECTION INDICATORS AND REAR REGISTRATION PLATE LAMPS FOR L GROUP VEHICLES**

Specifies the photometric requirements for light-signalling devices fitted to motor cycles and mopeds that signal to other road users the position, orientation and movement of the vehicle without producing undue glare for other road users.

## **ADR 55 HEADLAMPS FOR MOTOR CYCLES.**

Specifies the photometric requirements for headlamps fitted to motor cycles that provide adequate illumination for the driver of the vehicle without producing undue glare for other road users.

## **ADR 60 CENTRE HIGH-MOUNTED STOP LAMP**

Requires a supplementary Centre High-Mounted Stop Lamp on the rear of the vehicle to provide an additional indication to other road users that the driver of the vehicle is applying the service brakes.

### **ADR 61 VEHICLE MARKING**

Specifies vehicle marking requirements, such as identification numbers which were previously contained in ADR 42/....

### **ADR 62 MECHANICAL CONNECTIONS BETWEEN VEHICLES**

Specifies requirements for connections between vehicles including couplings, drawbars and safety chains.

### **ADR 67 INSTALLATION OF LIGHTING AND LIGHT-SIGNALLING DEVICES ON THREE-WHEELED VEHICLES**

Specifies requirements to ensure the effective operation of lighting and light signalling devices fitted to three wheeled vehicles.

### **\*ADR 70 EXHAUST EMISSION CONTROL FOR DIESEL ENGINED VEHICLES**

**Repealed;** This standard has been superseded by ADR 79/... for new light vehicles and ADR 80/... for new heavy vehicles as from 1 October 2006.

Limits exhaust emissions on diesel-engine vehicles.

### **ADR 75 HEADLAMP CLEANERS (IF FITTED)**

Specifies the installation and testing of headlamp cleaners that are fitted to motor vehicles. Details for whether headlight cleaning devices are compulsory, optional or prohibited are set out in ADR 13/..., 19/... or 67/...

### **ADR 76 DAYTIME RUNNING LAMPS (IF FITTED)**

Specifies the photometric requirements of daytime running lamps that are intended to increase the conspicuity of a vehicle during daylight. Details for whether daytime running lamps are compulsory, optional or prohibited are set out in ADR 13/..., 19/... or 67/....

### **ADR 77 GAS DISCHARGE HEADLAMPS**

Specifies the photometric requirements of motor vehicle headlamps that are fitted with gas discharge type headlamps. Details for whether gas discharge headlamps are compulsory, optional or prohibited are set out in ADR 13/..., 19/... or 67/....

### **ADR 78 GAS DISCHARGE LIGHT SOURCES**

Specifies the dimensional, photometric and electrical requirements of gas discharge light sources to ensure such light sources are interchangeable between different gas discharge headlamps and so that they function properly when installed in gas discharge headlamps.

### **ADR 83 EXTERNAL NOISE**

Defines limits for external noise generated by motor vehicles, motor cycles and mopeds to reduce the contribution of motor traffic on urban and community noise levels.

#### **Note:**

ADRS marked with an asterisk have been repealed and do not apply to newly manufactured vehicles.

In-service vehicles built to comply with these repealed ADRs must continue to comply with these requirements. Similarly vehicles built to comply with these repealed ADRs must continue to comply these ADRs after modification.

However it also acceptable to meet the standards of the ADR or provisions that superseded the repealed ADR. For example a vehicle built to comply with ADR 16/00 *Windscreen Wipers and Washers* that has its wipers and washers modified, will still be deemed to comply if the completed modification complies with the *windscreen and washer* provisions of ADR 42/04 *General Safety Requirements*.

## APPENDIX LE1-3 Seatbelt Mounting Examples

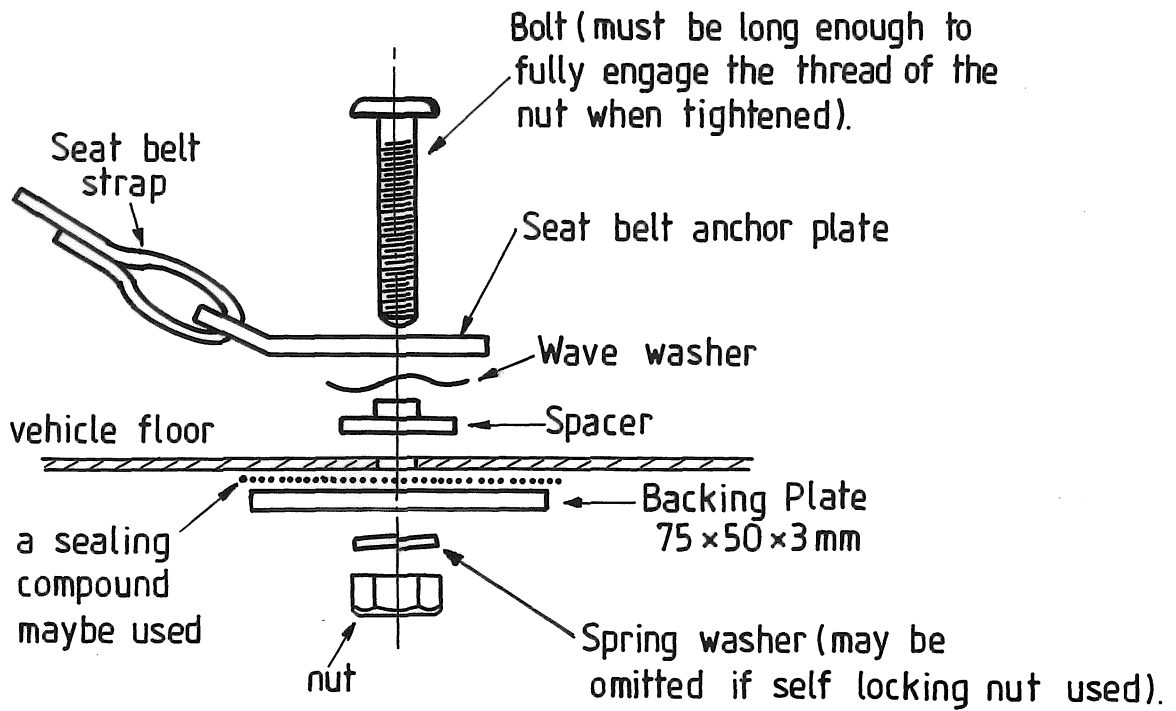

## **APPENDIX LE1-4**

### **Checklists**

The following checklists apply to LEM1 and LEP1 *trike* ICV construction:

- CODE LO4 LEM1 Category Tricycle Checklist; and
- CODE LO5 - LEP1 Category Tricycle Checklist.

Each checklist may be downloaded from the following Department of Infrastructure, Transport, Regional Development and Local Government website located at:-

**[www.infrastructure.gov.au](http://www.infrastructure.gov.au)**